

**STANDARD METHOD OF IMPACT TEST AND
PERFORMANCE REQUIREMENTS FOR
FOOTBALL FACEGUARDS**

NOCSAE DOC ND087 – 24

Prepared by

NOCSAE®

**NATIONAL OPERATING COMMITTEE ON
STANDARDS FOR ATHLETIC EQUIPMENT**

Revised January 2024
© 1973 NOCSAE

TABLE OF CONTENTS

Scope 1
Referenced Documents 1
Purpose 1
Test Sample Size..... 1
Test Requirements..... 4
Construction..... 5

JULY 2009 MODIFICATIONS/REVISIONS 8
DECEMBER 2009 MODIFICATIONS/REVISIONS 8
MAY 2010 MODIFICATIONS/REVISIONS..... 8
FEBRUARY 2011 MODIFICATIONS/REVISIONS 8
SEPTEMBER 2014 MODIFICATIONS/REVISIONS..... 8
OCTOBER 2014 MODIFICATIONS/REVISIONS 8
JUNE 2015 MODIFICATIONS/REVISIONS 8
JANUARY 2017 MODIFICATIONS/REVISIONS 8
JUNE 2017 MODIFICATIONS/REVISIONS 9
JULY 2017 MODIFICATIONS/REVISIONS..... 9
FEBRUARY 2018 MODIFICATIONS/REVISIONS 9
DECEMBER 2021 MODIFICATIONS/REVISIONS 9
JANUARY 2024 MODIFICATIONS/REVISIONS 9

1. Scope

- 1.1. This standard establishes methods of testing and performance requirements for new football faceguards as supplied by manufacturers. The requirements of this standard shall be subject to Level 3 compliance criteria unless otherwise stated herein.
- 1.2. **All testing and requirements of this standard specification must be in accordance with NOCSAE DOC 001 except where modified herein.**
- 1.3. *This standard does not purport to address all of the safety problems, if any, associated with its use. It is the responsibility of the user of this standard to establish appropriate safety and health practices and determine the applicability of regulatory limitations prior to use.*

2. Referenced Documents

- 2.1. NOCSAE DOC (ND) 001: *Standard Test Method and Equipment Used in Evaluating the Performance Characteristics of Headgear/Equipment*
- 2.2. NOCSAE DOC (ND) 002: *Standard Performance Specification for Newly Manufactured Football Helmets*

3. Purpose

- 3.1. To test new faceguards and attachment system to determine their fit, deflection, strength, suitability of guard and attachment design and materials, and shock absorbent properties. Recognition is made that the chinstrap system is part of this system.

4. Test Sample Size

- 4.1. For any standalone test report; at least two (2) sets of each faceguard model in each of the sizes intended to fit the medium headform must be tested. Faceguards shall be mounted to a football helmet that complies with ND002 and is listed by the faceguard's manufacturer as being compatible with and in a size that is appropriate for the protector. The faceguard may be installed by the manufacturer or may be installed by the test technician in accordance with supplied instructions. A different faceguard is to be used for each test position at each temperature condition.
- 4.2. Faceguards must be tested on every helmet model that the faceguard is intended to fit.
- 4.3. All faceguards shall be tested in accordance with Section 6.
- 4.4. Faceguards constructed with a structural terminus on the inner surface of the facial cutout shall also be test in accordance with Section 7. Two (2) additional untested faceguards must be submitted for this test

5. Headgear Preparation

- 5.1. Headgear shall be tested complete, in the condition as offered for sale.
- 5.2. Headgear used for testing shall be selected in a random manner.

- 5.3. Faceguards offered only in sizes intended to fit 7 ³/₈– 7 ⁷/₈ size range helmets shall be shimmed or pressurized in the rear or side and tested on the medium headform.
- 5.4. Conditioning Environments
- 5.4.1. Ambient Temperature: Expose product to conditioned temperature of 72°F ± 3° F for a minimum of four hours.
- 5.4.2. High Temperature: Expose product to conditioned temperature of 100° F ± 3° F (39° ± 1° C) for at least four hours and a maximum of twenty-four (24) hours.
- 5.4.3. Low Temperature: Expose product to conditioned temperature of 32°F +0/-3°F (0°C +0/-1°C) for at least four hours.
- 5.4.4. When performing conditioned environment temperature testing, the first impact shall occur between the 1st and 2nd minute after removing the sample from the conditioning environment. The second impact shall occur 75 seconds (± 15 sec) after the first impact, etc. If the sample cannot be tested within these time constraints, the sample must be returned to the conditioning environment for a minimum of 3 minutes for each minute the sample was out of the conditioning environment. Conditioning must be complete before testing can resume on that sample.
- 5.5. Drop Test Helmet Positioning
- 5.5.1. Prior to each drop, fit the helmet on the size medium headform such that the ear holes are concentric with the headform ear index holes and the front rim is located with the HPI supplied by the manufacturer of the helmet or according to the helmet manufacturer's fitting instructions. The headform and helmet shall be dry to maximize friction. Secure the helmet with the chinstrap and procedure specified by the manufacturer. Measure and record the distance from nose and chin of the model in the midsagittal plane, and the inside surface of the faceguard (standoff distance). The helmet shall be positioned within the extents allowed by the manufacturers fitting instructions so that the standoff measurements can be investigated to ascertain if both nose and chin distances can be adjusted to less than 2 ³/₄ inches (70 mm) which shall be the position used for impact testing. Note that if the manufacturer supplies a HPI then the measurements shall be made at that position only.
- 5.5.2. Measurement Points and Procedure: The nose and chin points are located on the midsagittal plane on the face of the headform distal from the coronal plane. The nose point is 0.650" below the basic plane on the medium headform; the chin point is located 3.400" below the basic plane on the medium headform. See figure 1 NOCSAE DOC 001. Faceguard standoff measurements will be made parallel to the basic plane to the inside surface of the guard. Should the guard not have a surface on the line projected from the measurement spot toward the faceguard then a surface shall be created using a material that is able to conform to the inside surface of the guard components adjacent to the measurement points in a way that will provide a reference surface at the desired point for the measurement. The thickness of this measurement aid should be as thin as practical and will be accounted for in the measurement so that a very close approximation ± .025" of the

true measure of the stand-off distance is obtained. For headforms with an indicator groove molded in to locate the midsagittal plane, measurements may be made from the immediately adjacent surface so as to avoid the measurement probe from engaging the depth of the groove, or the groove may be filled with a material to prevent the probe from entering. In either case the measurement point on the headform must be flush with the surface of the outward edges of the groove.

6. Impact Attenuation Tests

- 6.1. Each submitted sample shall be impacted in accordance with Table 1 below and as depicted in Figure 1.
- 6.1.1. All faceguards shall be drop tested at the Front impact location. Only faceguards that meet the requirements of 6.1.2 below shall be impacted at the Bottom impact location.
- 6.1.2. Bottom Impact Location: Complete the following steps to determine if faceguards require drop tests on the bottom location.
- 6.1.2.1. Fit the helmet onto the headform as described in Section 5.5.
- 6.1.2.2. Adjust the drop fixture so it is placed in the Bottom Impact Location position. Pin locations for this position are shown in Figure 1.
- 6.1.2.3. Extend a perpendicular line that originates from the top surface of the MEP. This line shall terminate at the center of the lowest point of the chin of the headform. If the surface that is created by and contained within the perimeter of the faceguard intersects the perpendicular line, the faceguard shall be subjected to Bottom Location impacts.
- 6.2. Impacts shall be conducted on the 1/8" Faceguard Test MEP

TABLE 1
Drop Test Impact Schedule
Velocity - ft/s (m/s) +3% -0%

Conditioning Environment	IMPACT VELOCITY FT/S (M/S)	FRONT	BOTTOM
Ambient Temperature	13.89 (4.23)	X	X
	17.94 (5.46)	X	X
High Temperature	17.94 (5.46)	X	
Low Temperature	17.94 (5.46)	X	

7. Rigid Mount Deformation Test

- 7.1. Condition the faceguard to be tested at ambient laboratory temperature for a minimum of four hours prior to testing.
- 7.2. Create a test jig (see figure 2) that will allow the faceguard to be held as rigidly as possible using mounting locations as close to the helmet mount locations as reasonably possible.
- 7.3. Place the test jig with rigidly mounted faceguard in a suitable compression test device capable of a crosshead speed of at least 10 inch per minute.
- 7.4. Use an approximate 1-inch diameter flat steel face plunger, align the rigidly mounted faceguard so that the plunger compresses the apex of the faceguard.
- 7.5. Compress the faceguard with a crosshead speed of $10 \pm 3\%$ inches per minute so as to deflect the outside apex of the guard inwards until the deflection distance reaches 3 ± 0.25 inches or until the applied force reaches 1,100 lbf.
- 7.6. Record the resultant peak pounds force and total deflection of the guard.

8. Test Requirements

8.1. Impact Attenuation Tests

- 8.1.1. The peak severity index of any impact shall not exceed 1200 SI.
- 8.1.2. The faceguard shall not contact the face during the 13.89 ft/s drop as determined by contact paste or carbon paper transfer, electrical contact, or another equivalent technique.
- 8.1.3. Contact with the chinstrap/chin cup shall be a failure, however, if the model passes with the thinnest chinstrap/chin cup offered by the manufacturer for that helmet/faceguard combination but makes contact on thicker chinstrap/chin cup options for that helmet/faceguard combination that shall not be judged as a failure.
- 8.1.4. No structural failure allowed, e.g.: fracture or cracked weld or broken attachment on any drop this includes chin strap systems.
- 8.1.5. The faceguard or any of its component attachment parts shall not fail in terms of cracked welds, broken screws, broken T nuts, strap tears or pull-outs.

8.2. Faceguard Standoff Measurements

- 8.2.1. The standoff measurements for both the nose and chin obtained in Section 5.5 shall not exceed 2.75 inches (70 mm).
- 8.2.2. Should the guard's lower perimeter fall completely above the chin measurement location described in Section 5.5 at the extents of typical fitting as determined by the technician, then that guard cannot be certified.

8.3. Rigid Deformation Test

- 8.3.1. The peak force shall not be less than 550 lbs. force and there shall be no mechanical failure resulting in an exposed material end.

9. Construction

- 9.1. General: Headgear is worn on the head in an effort to reduce or minimize injury to that portion of the head within the specified area of coverage. Headgear shall be constructed to reduce the risk of injury to the wearer and to remain on the wearer during impact. Optional devices fitted to the headgear shall be designed so they are unlikely to cause injury during use. For example: wire face protectors must not be designed with weld junctions and/or wire terminus ends in the ocular area, such that in the event of a weld separation, the wire ends could come into contact with the ocular area.
- 9.2. The protective equipment must survive all test protocols substantially intact and ready for use.
- 9.3. Projections: Internal rigid projections that may contact the wearer's head during impact shall be covered to reduce the likelihood of injury. Pressure sensitive film or electronic methods may be employed to evaluate the transmitted force of internal projections suspected to be a likely source of injury; such forces shall be limited to a maximum of 750 lbs/in².
- 9.4. Metallic Hardware as defined in NOCSAE DOC 001 shall meet the requirements of ND015 *Standard Test Method and Specification Used in Evaluating the Corrosion Characteristics and Effects on Metallic Hardware Disassembly*.
- 9.5. The choice of components shall be such as to combine mechanical strength and durability to impact loading over a temperature range from 0°F (-17°C) to 120°F (49°C). And shall be unlikely to fracture, delaminate or become broken, dislodged or separated in a manner that could result in a sharp object presentation that may induce injury.
 - 9.5.1. Components in mounting systems shall be compatible with one another. Mounting system components should not undergo significant loss of strength or other physical change as a result of contact with perspiration, blood, oil or grease from wearer's hair, or from exposure to ultra-violet rays.
 - 9.5.2. Finishes: All components shall be well finished and free of sharp edges and other irregularities which would present the potential hazards of scratching and cutting the user or an opposing player. Wire or metallic tubular protectors shall have protective coating.
 - 9.5.3. Attachment System: The method of attaching the faceguard to the helmet shall be such as to prevent the faceguard disengaging while under load and in use and in such a way as to minimize static distortion of attachment straps and helmet.
 - 9.5.4. All faceguard ends will be terminated with a full radius.

10. Labeling

10.1. Each faceguard shall be reasonably permanent and legibly labeled in a manner such that the following information can be easily read.

1. Name of Manufacturer
2. Model
3. Month and Year of Manufacture
4. "SEI Certified, Meets NOCSAE Standard®"

10.2. The manufacturer shall make publicly available a list of NOCSAE compliant helmet models on which the faceguard has been tested and certified as meeting this Standard Performance Specification.

NOTE: You must have an executed, valid license agreement with NOCSAE to use any of the NOCSAE marks at any time. NOCSAE, the NOCSAE marks, and the National Operating Committee on Standards for Athletic Equipment are registered marks and the exclusive property of the Committee. Use of the marks in any manner is prohibited without prior written permission of the NOCSAE Board of Directors.

10.3. The manufacturer shall make publicly available a list of NOCSAE compliant helmet models on which the faceguard has been tested and certified as meeting this Standard Performance Specification.

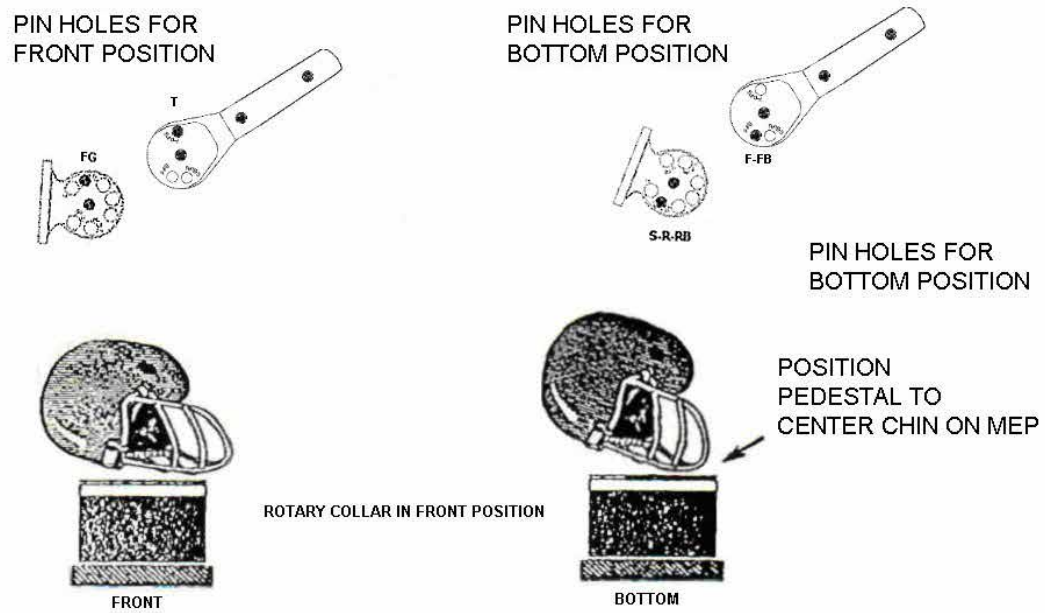

Figure 1

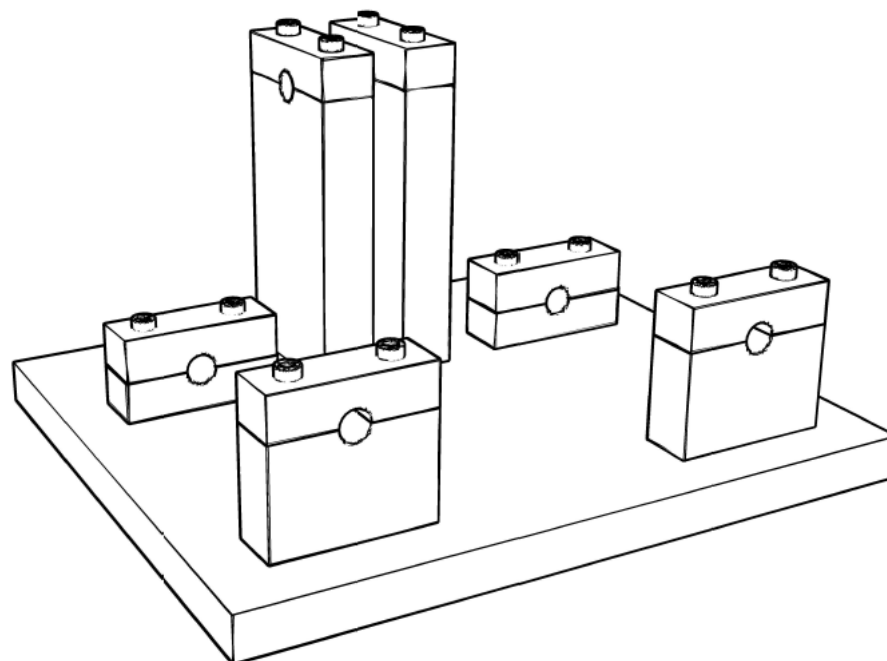

Figure 2

The Faceguard Test Jig shall be configured and dimensioned appropriately so as to rigidly hold the guard in a manner that uses similar attachment points as when the guard is mounted to a helmet.

JULY 2009 MODIFICATIONS/REVISIONS

- REVISION: Specified that chinstrap and associated hardware are subject to the requirements in section 5
- REVISION: Changed section 7 to clarify faceguard to face measurement procedure.
- Modified sections 8.3.4 and 8.3.5 to clarify SI requirements

DECEMBER 2009 MODIFICATIONS/REVISIONS

- Modified conditioning environments to conform with NOCSAE DOC 001 requirements

MAY 2010 MODIFICATIONS/REVISIONS

- REVISION: Changed bottom impact location. Modified figure 1 to specify pinhole locations. Changed requirements for bottom impact location. Deleted faceguard types.

FEBRUARY 2011 MODIFICATIONS/REVISIONS

- REVISION: Change drop heights to drop velocities. Corrected typos

MAY 2012 MODIFICATIONS/REVISIONS

- REVISION: section 5.2, chin cup contact and section 6.2.6, faceguard coverage requirement
- Added labeling requirement in section 6, for model identification
- Added statements to clarify sections 7.1 and 7.4

SEPTEMBER 2014 MODIFICATIONS/REVISIONS

- Added reference to ND001 for faceguard MEP specifications
- Clarified section 8.3.2
- Corrected typo in section 8.3.5

OCTOBER 2014 MODIFICATIONS/REVISIONS

- Updated document to include level of compliance requirements.
- Added Date specification becomes effective
- Updated title name of NOCSAE DOC. 001
- Added SEI Certification NOCSAE Logo to Section 6.1, "Labeling"

JUNE 2015 MODIFICATIONS/REVISIONS

- Updated NOCSAE seal/logo artwork

JANUARY 2017 MODIFICATIONS/REVISIONS

- REVISION: Increased low temperature conditioning requirement to 0°F from -20°F.
- Clarified 8.4.4 for bottom impact location requirement
- Clarified maximum standoff requirement

- Added section requiring a list of compatible helmets on which faceguard has been tested.

JUNE 2017 MODIFICATIONS/REVISIONS

- Changed the word “specimen” to “sample” in Section 8.4.2.
- Changed the word “model” to “sample” in Section 8.4.2.

JULY 2017 MODIFICATIONS/REVISIONS

- Section 5.3 – Changed reference from section 7 to section 8.

FEBRUARY 2018 MODIFICATIONS/REVISIONS

- REVISION: Added provision to address alternative faceguard design and added a test method and performance criteria to evaluate those designs
 - Changed section 6.2.4
 - Added section 6.2.5 to address multiple faceguard design requirements
 - Added section 5.6, requirements for deformation test
 - Added section 9, Rigid Mount Deformation Test procedure
- Removed material skin disease language
- Corrected typos and reformatted document
- Added Figure 2

DECEMBER 2021 MODIFICATIONS/REVISIONS

- Edited sections 6.2.4 and 6.2.5 to clarify testing requirements based on faceguard design.
- Edited rigid mount deformation test procedure to include maximum deformation and compressive force values.

JANUARY 2024 MODIFICATIONS/REVISIONS

- REVISION: Faceguard recertification procedures and requirements moved to new document – ND089
- Reorganized document for clarity and consistency with other NOCSAE standards