

**STANDARD PERFORMANCE
SPECIFICATION FOR
NEWLY MANUFACTURED
POLO HELMETS**

NOCSAE DOC (ND) 050 – 11m19

Prepared By



**NATIONAL OPERATING COMMITTEE
ON STANDARDS FOR ATHLETIC EQUIPMENT**

Modified December 2019

TABLE OF CONTENTS

Scope	1
Referenced Documents.....	1
Specific Terminology	1
Test Sample Size	1
Helmet Preparation	1
Testing Sequence	2
Retention Testing	2
Helmet Stability Testing.....	2
Impact Attenuation Tests.....	2
TABLE 1	3
Temperature.....	3
TABLE 2	3
TABLE 3	4
Test Requirements	4
Labels and Warnings.....	4
Figure 1	6
Figure 2	7
Figure 3	8
Figure 4	9
Figure 5	10
Figure 6	11
Figure 7	11
DECEMBER, 2004 MODIFICATIONS/REVISIONS	12
FEBRUARY 2011, MODIFICATIONS/REVISIONS	12
MAY 2012, MODIFICATIONS/REVISIONS	12
OCTOBER 2014 MODIFICATIONS/REVISIONS	12
OCTOBER 2014 MODIFICATIONS/REVISIONS	12
JUNE 2015 MODIFICATIONS/REVISIONS	12
DECEMBER 2019 MODIFICATIONS/REVISIONS	12

1. Scope

- 1.1. This standard specification establishes performance requirements for new polo helmets as supplied by manufacturers. The requirements of this standard shall be subject to Level 3 compliance criteria unless otherwise stated herein.
- 1.2. ***All testing and requirements of this standard specification must be in accordance with NOCSAE DOC.001, except where modified herein.***
- 1.3. *This standard does not purport to address all of the safety problems, if any, associated with its use. It is the responsibility of the user of this standard to establish appropriate safety and health practices and determine the applicability of regulatory limitations prior to use.*

2. Referenced Documents

- 2.1. STANDARD DROP TEST METHOD AND EQUIPMENT USED IN EVALUATING THE PERFORMANCE CHARACTERISTICS OF HEADGEAR/EQUIPMENT, NOCSAE DOC.001

3. Specific Terminology

- 3.1. See Section 3, NOCSAE DOC.001.
- 3.2. High Temperature: Expose product to conditioned temperature of 100°F ± 3°F (39° ± 1°C) for at least four hours and a maximum of twenty-four (24) hours.

NOTE: When performing conditioned environment temperature testing, the first impact shall occur between the 1st and 2nd minute after removing the sample from the conditioning environment. The second impact shall occur 75 seconds (± 15 sec) after the first impact, etc. If the sample cannot be tested within these time constraints, the sample must be returned to the conditioning environment for a minimum of 3 minutes for each minute the sample was out of the conditioning environment. Conditioning must be complete before testing can resume on that sample.

4. Test Sample Size

- 4.1. See Sections 6 and 11, NOCSAE DOC.001, for QC/QA protocol testing.
- 4.2. For any standalone test report; at least three (3) of each model in each critical size must be tested. Two (2) will be tested at ambient; one (1) tested at high temperature.

5. Helmet Preparation

- 5.1. See Section 10, NOCSAE DOC.001
- 5.2. Eye Protectors: During all testing the helmets must be tested without the eye protector (mask) attached.
- 5.3. Helmets of a given model with a size smaller than 6 5/8 may not fit the smallest NOCSAE headform. In that event, testing of that size is waived so long as the other sizes of that model have been tested and meet all requirements.

- 5.4. To obtain a reasonable fit (as determined by the test technician) for testing purposes, helmets larger than size 7 5/8 may require "shim" pads to be inserted between the largest NOCSAE headform and the interior of the helmet, opposite from the impact site.

6. Testing Sequence

- 6.1. The retention and roll-off tests described below shall be performed prior to any of the impact tests.

7. Retention Testing (Neck Strap)

- 7.1. An ambient temperature conditioned helmet, while seated on a head shaped platform, shall be subjected to a dynamic strength retention test on the primary retention system using a Retention System Strength and Extension apparatus (see Figure 1). Said apparatus shall include two metal bars each with a diameter of 0.5 ± 0.02 in (12.7 ± 0.5 mm) that have a center distance of 3.0 ± 0.04 in (76.0 ± 1 mm).
- 7.2. The retention system fastening device shall be aligned with the strap fixture so that no part of the retention system fastening device shall contact the strap fixture prior to release of the drop mass. The entire dynamic test apparatus shall hang freely on the retention system. The entire mass of the support assembly, excluding drop weight, must be 15.5 lb (7.03 kg) $\pm 5\%$.
- 7.3. A 9 ± 0.2 lb (4.1 ± 0.08 kg) drop mass shall be allowed to free-fall onto the stop anvil from a height of 2.0 feet ± 0.25 inch (61 cm ± 6 mm). The retention system shall remain intact without elongating by more than 1.25 inches (31.75 mm).
- 7.4. A helmet conditioned at ambient temperature shall be subjected to this test.

8. Helmet Stability Testing

- 8.1. A helmet stability (roll-off) stand is depicted in Figure 2 and shall include a guide rod and stop anvil (see Figure 3) similar to that used in the Retention System test, minus the strap fixture (two rods). This guide apparatus shall weigh 2.5 ± 0.5 lb (1.13 ± 0.23 kg).
- 8.2. A cable and attached hook connect the guide rod to the far edge of the helmet. The cable and hook shall weigh less than 0.45 lb. (0.2 kg). The hook shall engage no less than $\frac{1}{2}$ linear inches (12.7 mm) of the helmet edge.
- 8.3. An ambient temperature conditioned helmet shall be affixed to the correct size NOCSAE headform in accordance with the manufacturer's instructions with only the primary retention system adjusted as described in those instructions. This helmet shall then be subjected to a positional stability test by allowing a 9 lb. (4.08 kg) drop mass to pull on the back edge of the helmet when dropped from a height of 2 feet (0.61 m). During this test the headform will be canted downwards at a 45° angle from vertical and facing the floor. The helmet shall remain on the headform upon the completion of this test.

9. Impact Attenuation Tests

- 9.1. Impact locations are described in Section 19, NOCSAE DOC.001 and in Figure 4 attached.

- 9.2. The impact locations on helmets with a sun visor shall be obtained using the locator holes on the Positioner Adjuster and/or Stem which will allow an impact to be centered around the desired impact point on the helmet closest to the standard location which clears the visor (and eye protector) from contacting the Test MEP pad or anvil throughout the impact. Those helmets without visors must be tested in the standard NOCSAE locations.
- 9.3. The random location chosen cannot be less than 1 inch (25 mm) from the any previous impact
- 9.4. The first submitted sample helmet shall be impacted in accordance with Table 1 below and as depicted in Figure 5. The ambient conditioned helmet shall be impacted once in each of the standard positions plus a random position from a velocity of 17.94 ft/sec onto either the hemispherical anvil (see Figure 6) or equestrian hazard anvil (see Figure 7) in any sequence but at least one impact must be made to each anvil.
- 9.5. The hemispherical anvil shall have a spherical surface with a radius of 48 ± 1 mm. The spherical surface shall constitute one half of the surface of a sphere.
- 9.6. The circular portion of the equestrian hazard anvil shall have a radius of 66.7 ± 0.5 mm, with facial surfaces inclined at an angle of $45 \pm 2^\circ$. The edge rail at the intersection of the facial surfaces shall have a radius of 0.4 mm maximum.

TABLE 1

LOCATION - DROP velocities – ft/s (m/s)
(All drop velocities must be within +3% -0%)

Ambient Temperature	Anvil To Use	FRONT	RIGHT SIDE	RIGHT F. BOSS	RIGHT R. BOSS	REAR	TOP	RANDOM
	Hemispherical and Equestrian	17.94 (5.46)	17.94 (5.46)	17.94 (5.46)	17.94 (5.46)	17.94 (5.46)	17.94 (5.46)	17.94 (5.46)

- 9.7. The second submitted sample shall be tested as per Table 2 below and as also depicted in Figure 5. The ½” Test MEP pad shall be used for these three impacts which shall be performed in the sequence shown for each position.

TABLE 2

LOCATION - DROP velocities – ft/s (m/s)
(All drop velocities must be within +3% -0%)

	FRONT	RIGHT SIDE	RIGHT F. BOSS	RIGHT R. BOSS	REAR	TOP	RANDOM
Ambient Temperature	11.34 (3.46)	11.34 (3.46)	11.34 (3.46)	11.34 (3.46)	11.34 (3.46)	11.34 (3.46)	11.34 (3.46)
	17.94 (5.46)	17.94 (5.46)	17.94 (5.46)	17.94 (5.46)	17.94 (5.46)	17.94 (5.46)	17.94 (5.46)
	17.94 (5.46)	17.94 (5.46)	17.94 (5.46)	17.94 (5.46)	17.94 (5.46)	17.94 (5.46)	17.94 (5.46)

- 9.8. The third submitted sample shall be tested as per Table 3 below and as also depicted in Figure 5. At least two (2) locations are selected by determining which two of the highest previous 60-inch ambient temperature locations tests (above) yielded the highest severity indexes. Again, the ½” Test MEP pad is used as the impact surface.

TABLE 3

LOCATION - DROP velocities – ft/s (m/s)
(All drop velocities must be within +3% -0%)

	FRONT	RIGHT SIDE	RIGHT F. BOSS	RIGHT R. BOSS	REAR	TOP	RANDOM
High Temperature	17.94 (5.46)	17.94 (5.46)	17.94 (5.46)	17.94 (5.46)	17.94 (5.46)	17.94 (5.46)	17.94 (5.46)
	17.94 (5.46)	17.94 (5.46)	17.94 (5.46)	17.94 (5.46)	17.94 (5.46)	17.94 (5.46)	17.94 (5.46)

10. Test Requirements

- 10.1. The peak severity index of any impact shall not exceed 1200 SI.
- 10.2. The 11.34 ft/s impacts designated in Table 2 must not exceed 300 SI*.
- 10.3. Helmet repositioning during testing is anticipated. Any structural changes or other changes that take place during impact testing which result in un-restorable, loosening of the fit (see Section 20, NOCSAE DOC.001) shall be cause for failure. In the case of helmets “shimmed” as per section 4.4, the replacement or repositioning of shims is allowed.
- 10.4. A passing helmet model is able to withstand all impacts at an acceptable SI and meets all other requirements when tested in accordance with this performance specification.

11. Labels and Warnings

- 11.1. See Section 9, NOCSAE DOC.001 and NOCSAE DOC.021.
- 11.2. Each helmet shall have permanently affixed to the exterior of the shell a clearly legible statement which can be easily read without removal of any decal tape, other temporary material or permanent part, which contains language which effectively communicates to the purchaser and user the following information, using the same or similar language:

WARNING

DO NOT USE THIS HELMET IF THE SHELL IS CRACKED OR DEFORMED OR IF THE INTERIOR PADDING IS DETERIORATED. SEVERE HEAD OR NECK INJURY, INCLUDING PARALYSIS OR DEATH MAY OCCUR TO YOU DESPITE USING THIS HELMET. NO HELMET CAN PREVENT ALL HEAD INJURIES OR ANY NECK INJURIES A PLAYER MIGHT RECEIVE WHILE PARTICIPATING IN POLO.

- ♦ This requirement shall be subject to Level 2 compliance criteria.

11.3. A permanent, exact replica of this seal must appear legibly on the exterior of the shell



NOTE: You must have an executed, valid license agreement with NOCSAE to use any of the NOCSAE logos at any time. NOCSAE, the NOCSAE seals/logos, and the National Operating Committee on Standards for Athletic Equipment are registered marks and the exclusive property of the Committee. Use of the marks in any manner is prohibited without prior written permission of the NOCSAE Board of Directors

This standard is subject to revision at any time by the responsible technical authority and must be reviewed every five years and if not revised either reapproved or withdrawn. Your comments are invited either for revision, modification or creation of additional standards and should be addressed to NOCSAE's Executive Director. Check the web at www.nocsae.org to obtain the latest version of a standard.

This standard is copyrighted by NOCSAE 11020 King St. Suite 215, Overland Park, Kansas 66210 USA. Copies may be obtained from the NOCSAE web site at www.nocsae.org

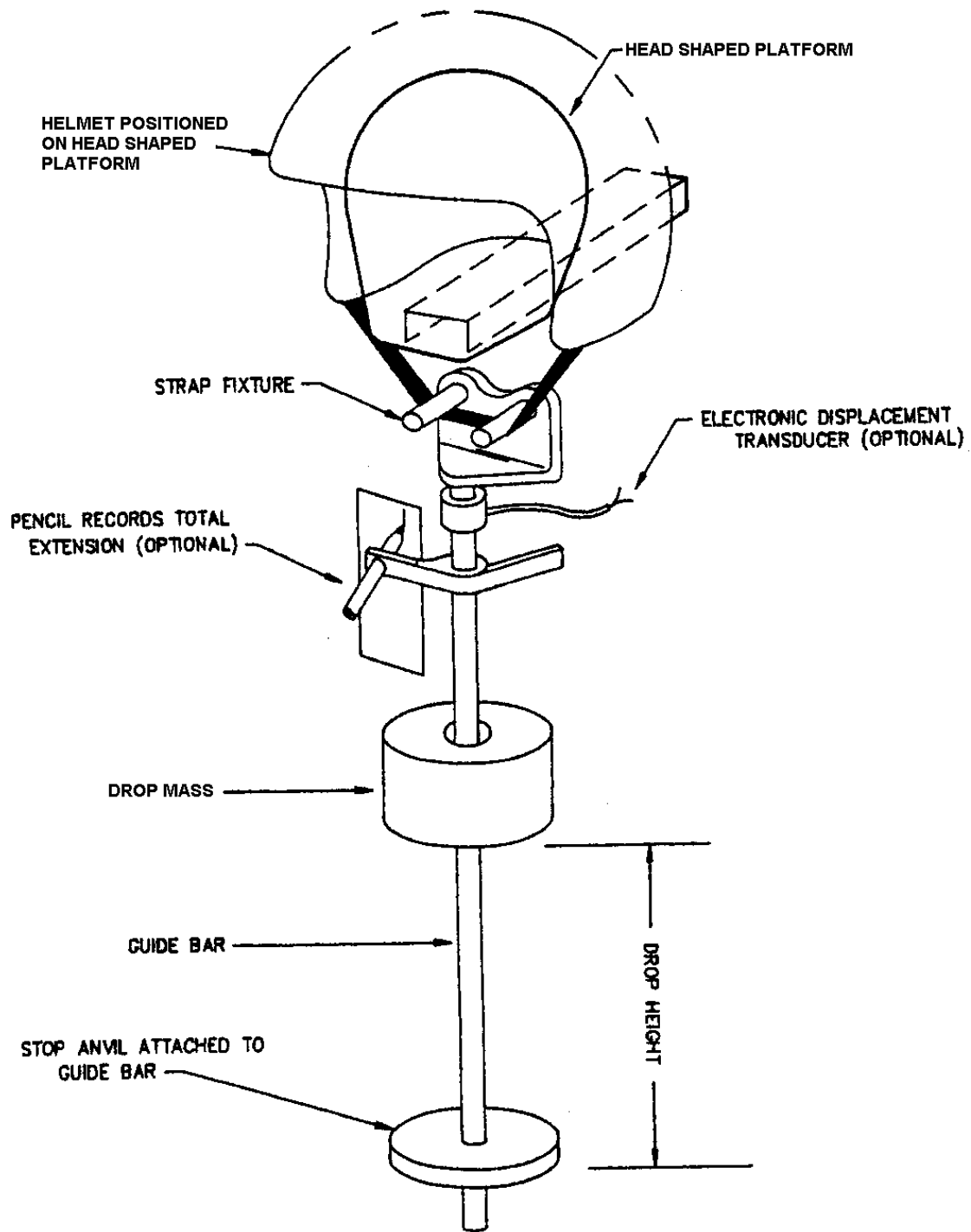

Figure 1

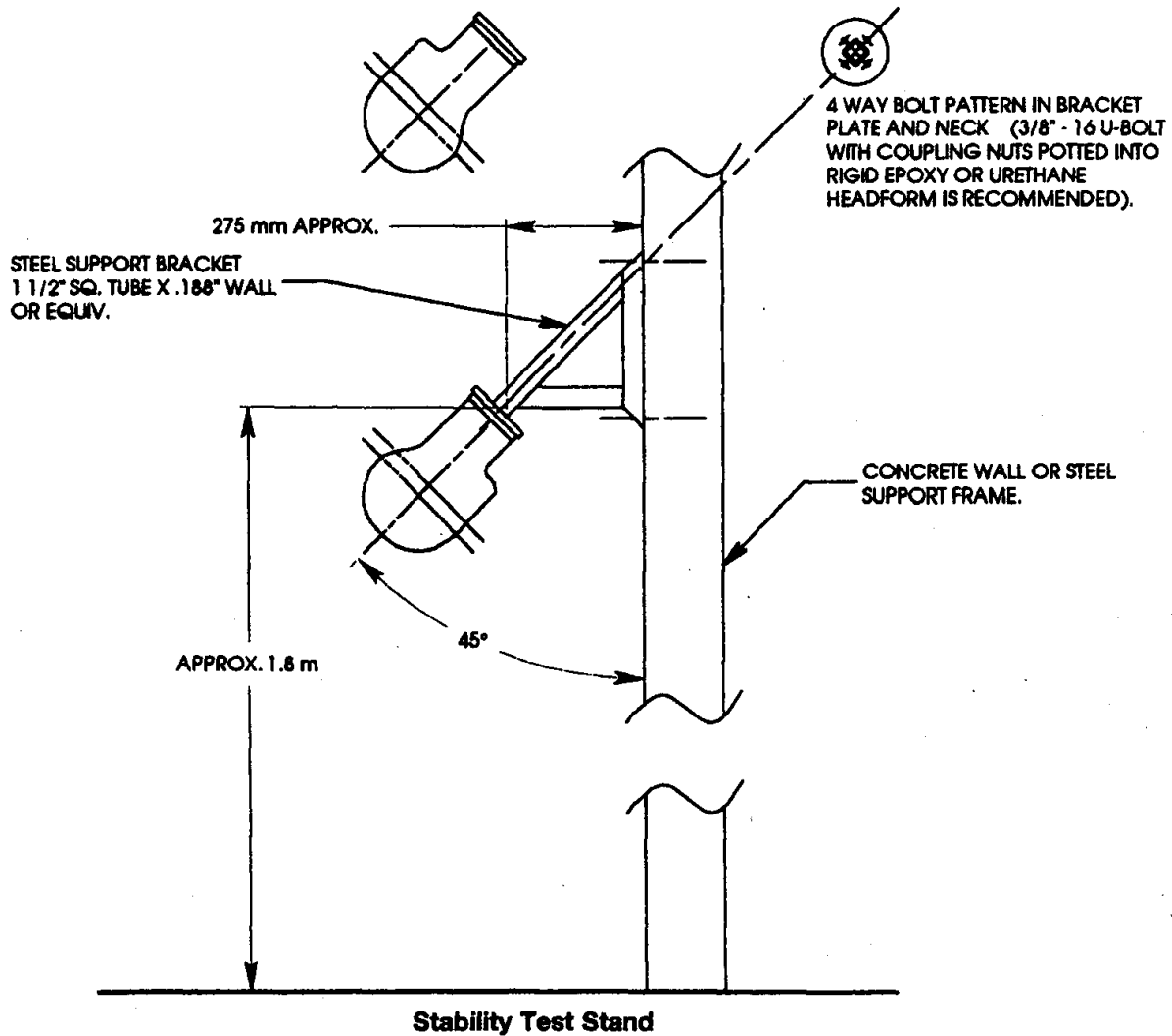

Figure 2

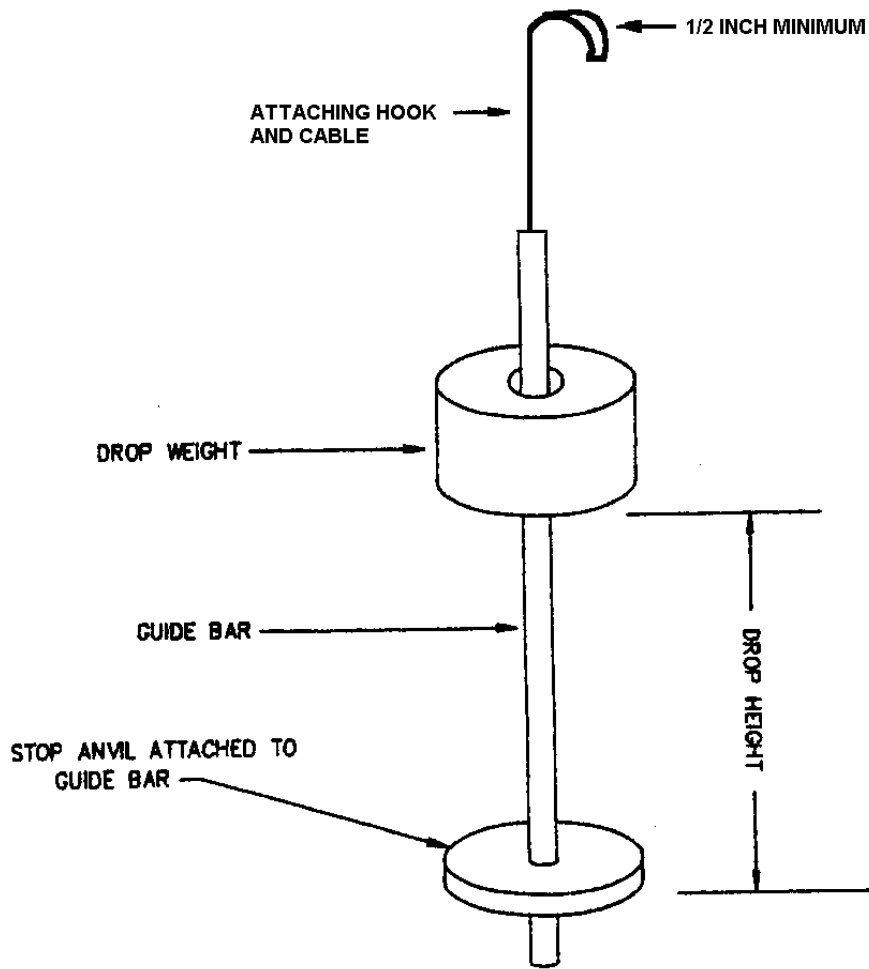
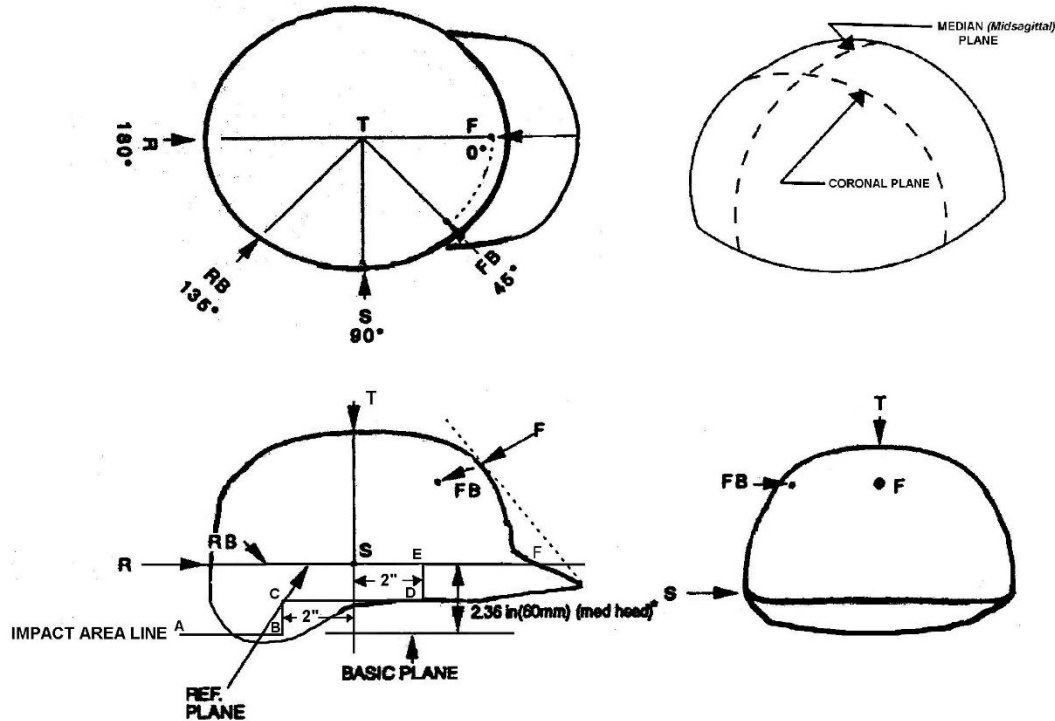

Figure 3

IMPACT LOCATIONS



* For the small headform the REFERENCE PLANE is 2.16 inches above the BASIC PLANE
For the large headform the REFERENCE PLANE is 2.48 inches above the BASIC PLANE

The random location may be selected from any point within the impact area but not closer than 1 inch (25mm) from the edge of the helmet nor less than 1 inch (25 mm) from any previous impact.

Random locations must allow rotator assembly to be locked in the position selected.

The impact area must include all locations on the head above the IMPACT AREA LINE

The impact area must include all locations on the head above the IMPACT AREA LINE (line A, B, C, D, E, F). For a helmet that is to be tested on the medium* headform. Point A is at the rearward intersection of the BASIC PLANE and MEDIAN PLANE. Point B is 2 inches rear of the intersection of the BASIC PLANE and CORONAL PLANE on the BASIC PLANE. Point C is 2 inches to the rear of the intersection of the BASIC PLANE and CORONAL PLANE and one half the distance from the REFERENCE to the BASIC PLANE. Point D is 2 inches forward of the intersection of the BASIC PLANE and CORONAL PLANE and one half the distance from the REFERENCE to the BASIC PLANE. Point E is on the REFERENCE PLANE 2 inches forward of the intersection of the BASIC PLANE and CORONAL PLANE. Point F is on the front intersection of the REFERENCE and MEDIAN PLANE.

* For the small headform use 1.75 inches (44 mm) and for the large headform use 2.25 inches (57 mm).

Figure 4

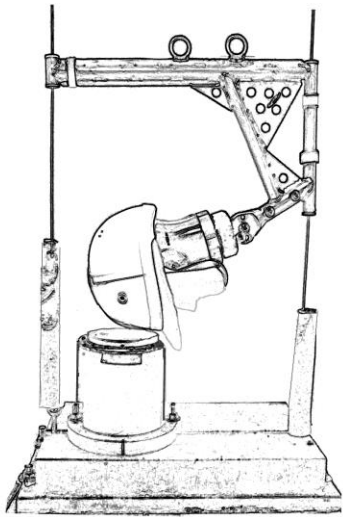

Front

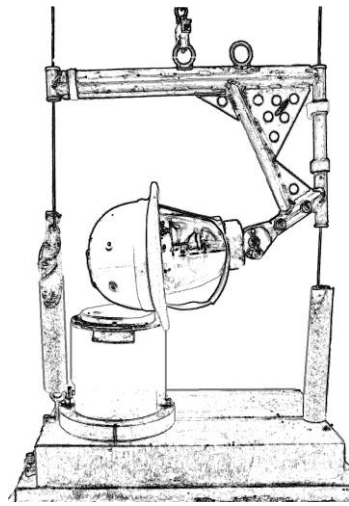

Right Side

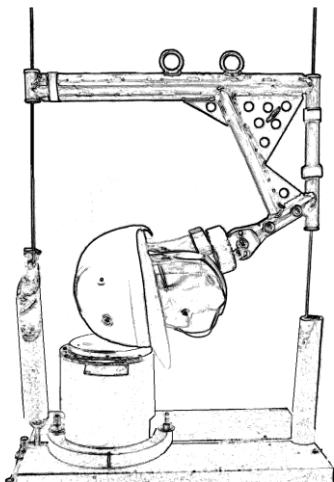

Right Front Boss

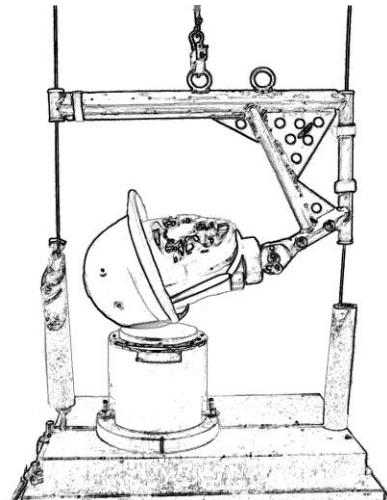

Right Rear Boss

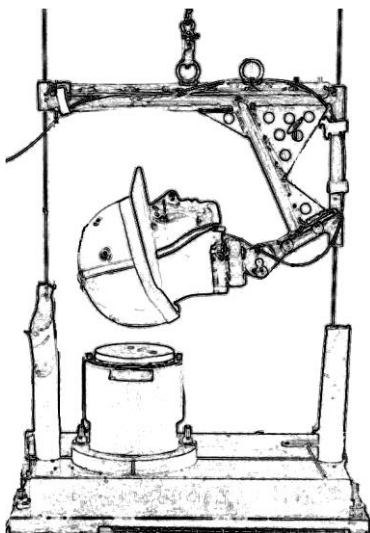

Rear

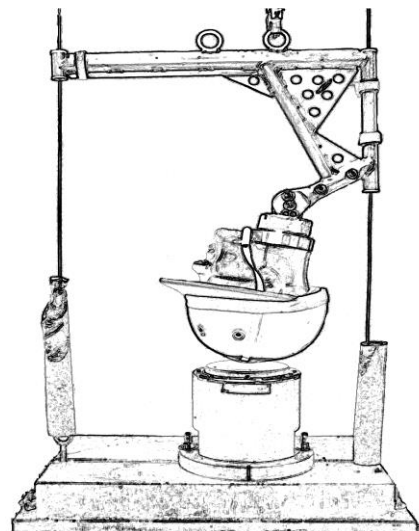

Top

Figure 5

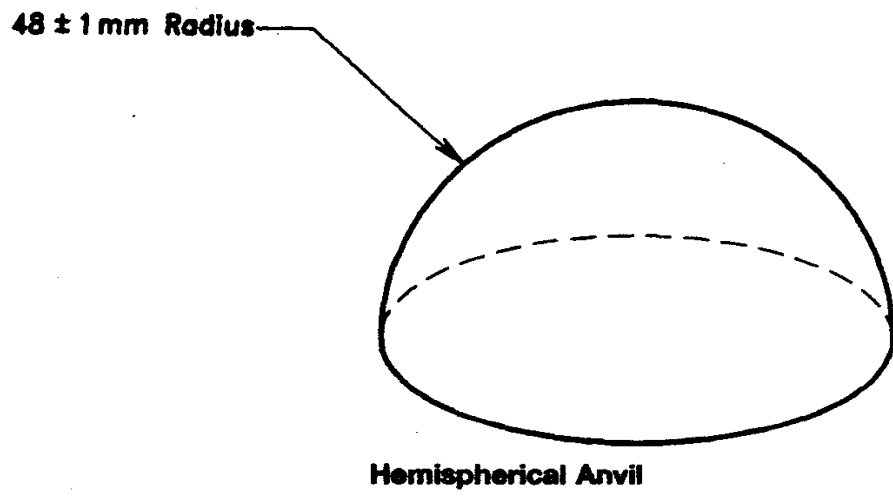
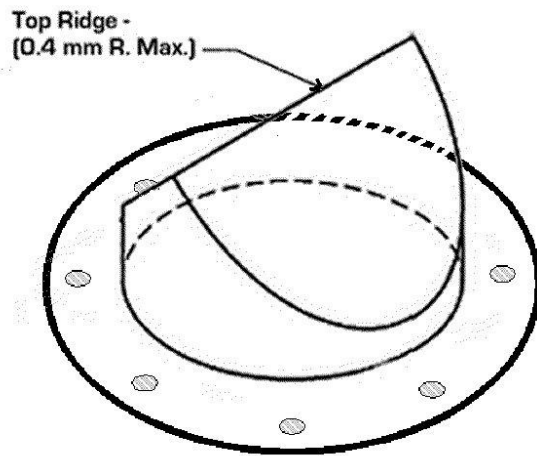

Figure 6



Equestrian Anvil

Figure 7

DECEMBER, 2004 MODIFICATIONS/REVISIONS

- **Revision-** Changed section 7 Retention Testing (Neck Strap) drop mass free fall to 2.0 ft and omitted drop mass free fall of 3.0 ft.
- **Revision-** Changed section 9.5 and Table 1 to omit second 60-inch impact onto the hazard anvils.

FEBRUARY 2011, MODIFICATIONS/REVISIONS

- **Revision-** Change drop heights to drop velocities. Moved test requirements to section 10. Clarified test requirements.

MAY 2012, MODIFICATIONS/REVISIONS

- Clarified section 4 for standalone test report
- Moved requirements to section 5 from section 4 for clarity
- Corrected reference from drop height to velocity.

OCTOBER 2014 MODIFICATIONS/REVISIONS

- Updated document to include level of compliance requirements.
- Added Date specification becomes effective
- Updated title name of NOCSAE DOC. 001
- Added SEI Certification NOCSAE Logo to Section 11, "Labels and Warnings"

JUNE 2015 MODIFICATIONS/REVISIONS

- Updated NOCSAE seal/logo artwork

DECEMBER 2019 MODIFICATIONS/REVISIONS

- Updated NOCSAE seal/logo artwork
- Changed references to face protector to eye protector