

**STANDARD PERFORMANCE
SPECIFICATION FOR
NEWLY MANUFACTURED
YOUTH FOOTBALL HELMETS**

NOCSAE DOC (ND)006-20

Prepared By



**NATIONAL OPERATING COMMITTEE
ON STANDARDS FOR ATHLETIC EQUIPMENT**

CAUTION: This standard is in “proposed” status. That status is exclusively for the purpose of encouraging comment and feedback to help develop a feasible and effective standard. By voting to move the document to “Proposed” status, the Standards Committee officially opened the comment and feedback period as provided in the NOCSAE standard development process.

There are significant portions that are not complete, including threshold performance values. No manufacturer is permitted to claim compliance with the standard and no governing body should require compliance. NOCSAE expects to receive significant input and feedback on all of these variables and encourages all stakeholders and interested parties to participate in the process.

Proposed Only

TABLE OF CONTENTS

Scope	1
Referenced Documents.....	1
Terminology	1
Sample Size	1
Helmet Preparation	1
Impact Attenuation Tests	2
Test Requirements.....	3
Labels and Warnings.....	3

Proposed Only

1. Scope

- 1.1 This standard specification establishes performance requirements for new youth football helmets as supplied by manufacturers.
- 1.2 **All testing and requirements of this standard specification must be in accordance with NOCSAE DOC001, except where modified herein.**
- 1.3 *This standard does not purport to address all the safety problems, if any, associated with its use. It is the responsibility of the user of this standard to establish appropriate safety and health practices and determine the applicability of regulatory limitations prior to use.*

2. Referenced Documents

- 2.1 NOCSAE DOC (ND) 001: *Standard Test Method and Equipment Used in Evaluating the Performance Characteristics of Headgear/Equipment*
- 2.2 NOCSAE DOC (ND) 081: *Standard Test Pneumatic Ram Test Method and Equipment Used in Evaluating the Performance Characteristics of Protective Headgear and Faceguards*

3. Terminology

- 3.1 Youth Football: Football played by persons who have not yet reached high school
- 3.2 Youth Player: Any player participating in Youth Football

4. Test Sample Size

- 4.1 See Sections 6 and 11, NOCSAE DOC 001 for QC/QA protocol testing.
- 4.2 For any standalone test report, at least four (4) of each model and size must be tested. Two helmets will be subjected to the drop test and two helmets will be subjected to the pneumatic ram test.

5. Helmet Preparation

- 5.1 See Section 10, NOCSAE DOC 001.
- 5.2 Face Guards: Helmets must be provided with face guards and face guard specific hardware when tested on the pneumatic ram and without face guards and face guard specific hardware.
- 5.3 A separate set of samples shall be used for each test method.
- 5.4 To obtain a reasonable fit (as determined by the test technician) for testing purposes, helmets larger than size 7 5/8 **may** require "shim" pads to be inserted between the largest NOCSAE headform and the interior of the helmet, opposite from the impact site.

- 5.5 Helmets of a given model with a size smaller than 6 5/8 **may** not fit the smallest NOCSAE headform. In that event, testing of that size is waived so long as the other sizes of that model have been tested and meet all requirements.
- 5.6 The jaw pads in the helmet may be replaced with a different thickness than originally supplied so that those pads firmly contact the headform jaw area, but without spreading the shell. This would be done prior to securing the chin strap to the chin of the headform.
- 5.7 High Temperature: Expose product to conditioned temperature of 100°F ± 3°F (39° ± 1°C) for at least four hours and a maximum of twenty-four (24) hours.

6. Impact Attenuation Tests

6.1 Drop Impact Test

- 6.1.1 Impact locations are described in Section 19, NOCSAE DOC 001.
- 6.1.2 Impacts shall be conducted on the Test MEP pad (see Section 15.2.2, NOCSAE DOC 001).
- 6.2 Each submitted sample helmet shall be impacted in accordance with Table 1.
- 6.3 At least two (2) locations, not to exceed four (4) locations, are to be selected for the high temperature impacts. This is accomplished by determining which of the 17.94 ft/s ambient temperature locations tested yielded the two highest severity indexes on each of the ambient samples. Those locations shall be tested at high temperature on each of the samples subjected to high temperature testing.

TABLE 1
LOCATION - DROP velocities – ft/s (m/s)
(All drop velocities must be within +3% -0%)

	FRONT	SIDE	F. BOSS	R. BOSS	REAR	TOP	RANDOM
Ambient	11.34 (3.46)	11.34 (3.46)	11.34 (3.46)	11.34 (3.46)	11.34 (3.46)	11.34 (3.46)	11.34 (3.46)
	13.89 (4.23)	13.89 (4.23)					
	16.04 (4.88)	16.04 (4.88)					
	17.94 (5.46)	17.94 (5.46)	17.94 (5.46)	17.94 (5.46)	17.94 (5.46)	17.94 (5.46)	17.94 (5.46)
	17.94 (5.46)	17.94 (5.46)	17.94 (5.46)	17.94 (5.46)	17.94 (5.46)	17.94 (5.46)	17.94 (5.46)
High Temperature	17.94 (5.46)	17.94 (5.46)	17.94 (5.46)	17.94 (5.46)	17.94 (5.46)	17.94 (5.46)	17.94 (5.46)
	17.94 (5.46)	17.94 (5.46)	17.94 (5.46)	17.94 (5.46)	17.94 (5.46)	17.94 (5.46)	17.94 (5.46)

NOTES: The high temperature condition impacts must be done after the ambient temperature impacts.

Impacts must be conducted in sequence from the lowest drop velocity through the highest for each location specified in table 1 above.

7. Pneumatic Ram Tests

- 7.1 Impact locations are described in NOCSAE DOC 081.
- 7.2 Impacts shall be conducted using the equipment described in *(to be determined)*
- 7.3 Each submitted sample helmet shall be impacted in accordance with Table 2 below.

TABLE 2
Pneumatic Ram Impact Location
Velocity – ft/s (m/s) $\pm 3\%$

SIDE	REAR BOSS CG	REAR BOSS NON CENTRIC	REAR	FRONT BOSS	RANDOM
16.4 (5.0)	16.4 (5.0)	16.4 (5.0)	16.4 (5.0)	16.4 (5.0)	16.4 (5.0)

8. Test Requirements

- 8.1 The peak severity index of any drop impact shall not exceed 1200 SI.
- 8.2 The 11.34 ft/s impacts designated in Table 1 shall not exceed 300 SI.
- 8.3 The peak severity index of any pneumatic ram test shall not exceed 1200 SI.
- 8.4 The peak rotational acceleration of any pneumatic ram test shall not exceed 2,000 rad/s².
- 8.5 The mass of the helmet including all accessories, attachments, and facemask shall not exceed 3.5 lbs. (1.59 kg).
- 8.6 Helmet repositioning during testing is anticipated. Any structural changes or other changes that take place during impact testing which result in un-restorable, loosening of the fit (see Section 20, NOCSAE DOC 001) shall be cause for failure. In the case of helmets that have been “shimmed”, the replacement or repositioning of shims is allowed.
- 8.7 A passing helmet model is able to withstand all impacts at an acceptable SI and meets all other requirements when tested in accordance with this performance specification.

9. Labels and Warnings

- 9.1 See Section 9, NOCSAE DOC.001.
 - 9.1.1 In addition to the labeling requirements specified in section 9.2 in NOCSAE DOC 001, a label that warns the user that this helmet shall be used by Youth Players participating in Youth Football only.
- 9.2 Each helmet shall have permanently affixed to the exterior of the shell a clearly

legible statement which can be easily read without removal of any decal tape, other temporary material or permanent part, which contains language which effectively communicates to the purchaser and user the following information, using the same or similar language:

WARNING

NO HELMET CAN PREVENT ALL HEAD OR ANY NECK INJURIES A PLAYER MIGHT RECEIVE WHILE PARTICIPATING IN FOOTBALL.

DO NOT USE THIS HELMET TO BUTT, RAM OR SPEAR AN OPPOSING PLAYER. THIS IS IN VIOLATION OF THE FOOTBALL RULES AND SUCH USE CAN RESULT IN SEVERE HEAD OR NECK INJURIES, PARALYSIS OR DEATH TO YOU AND POSSIBLE INJURY TO YOUR OPPONENT.

- 9.3 A permanent, exact replica of this seal must appear legibly on the exterior of the shell.



NOTE: You must have an executed, valid license agreement with NOCSAE to use any of the NOCSAE logos at any time. NOCSAE, the NOCSAE seals/logos, and the National Operating Committee on Standards for Athletic Equipment are registered marks and the exclusive property of the Committee. Use of the marks in any manner is prohibited without prior written permission of the NOCSAE Board of Directors.

This standard is subject to revision at any time by the responsible technical authority and must be reviewed every five years and if not revised either reapproved or withdrawn. Your comments are invited either for revision, modification, or creation of additional standards and should be addressed to NOCSAE's Executive Director. Check the web at www.nocsae.org to obtain the latest version of a standard.

This standard is copyrighted by NOCSAE 11020 King St. Suite 215, Overland Park, Kansas 66210 USA. Copies may be obtained from the NOCSAE web site at www.nocsae.org.

APPROXIMATE IMPACT LOCATIONS

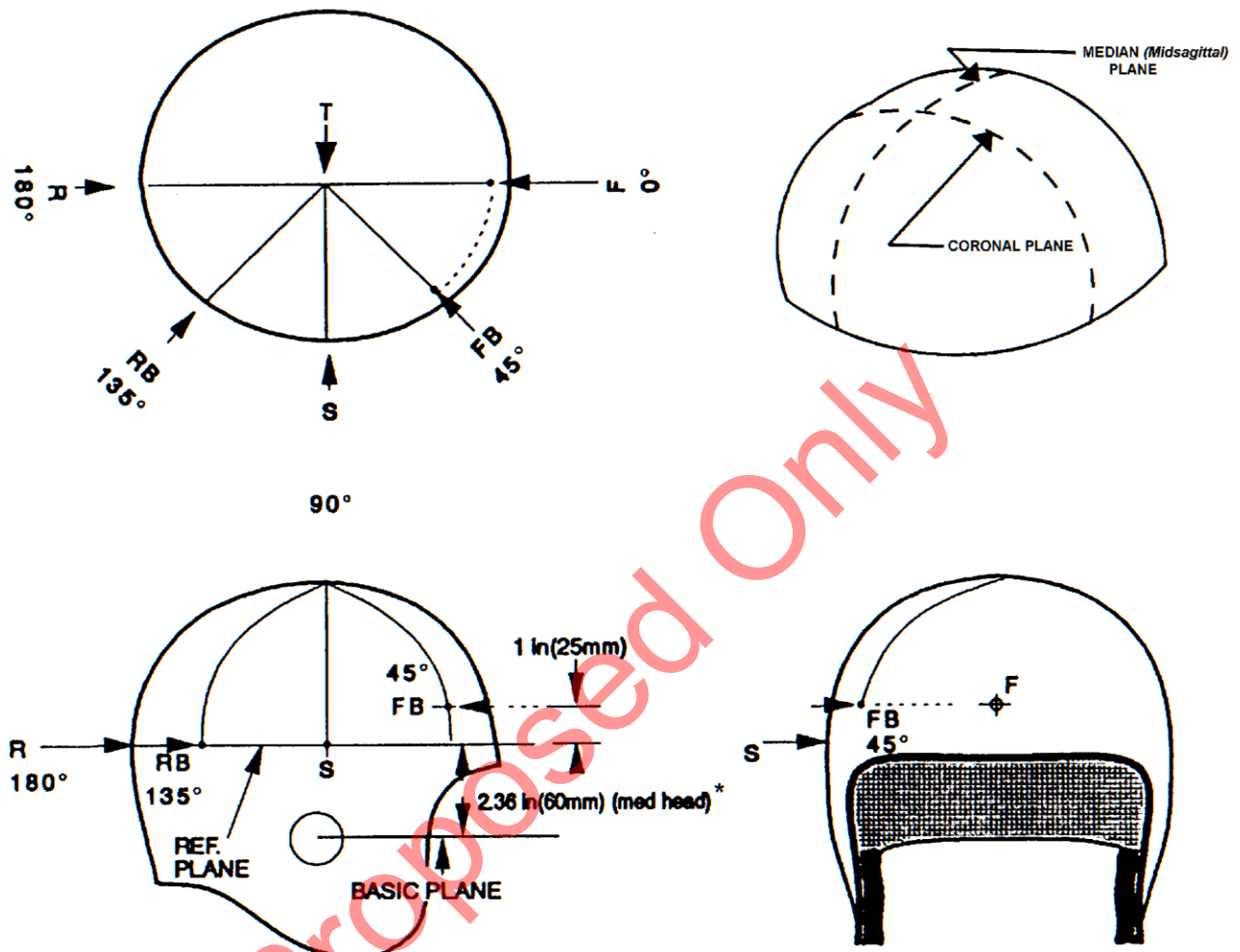

* For the small headform the REFERENCE PLANE is 2.16 inches above the BASIC PLANE. For the large headform the REFERENCE PLANE is 2.48 inches above the BASIC PLANE.

The random location may be selected from any point within the allowed impact area but not closer than 1 inch (25 mm) from the edge of the helmet nor less than 1 inch (25 mm) from any previous impact.

Random locations chosen must allow the rotator assembly to be locked in the position selected.

Impact Area - for a helmet that is to be tested on the medium headform*, the impact area must include all locations on the headform above the BASIC PLANE rearward of a location 2.5 inches (64 mm) forward of where the BASIC PLANE intersects with the CORONAL PLANE and any point on or above the REFERENCE PLANE in front of that same intersection.

* For the small headform use 2.25 inches (57 mm) and for the large headform use 2.75 inches (70 mm).

Figure 1