

**STANDARD PROJECTILE IMPACT TEST METHOD
AND EQUIPMENT USED IN EVALUATING THE
PERFORMANCE CHARACTERISTICS OF
PROTECTIVE HEADGEAR,
FACEGUARDS, OR PROJECTILES**

NOCSAE DOC (ND) 021 - 18m19

Prepared By



**NATIONAL OPERATING COMMITTEE
ON STANDARDS FOR ATHLETIC EQUIPMENT**

Revised: February 2018

TABLE OF CONTENTS

SCOPE	1
REFERENCED DOCUMENTS	1
SPECIFIC TERMINOLOGY	1
SIGNIFICANCE AND USE	2
SUMMARY OF TEST METHOD	2
CERTIFICATION	3
CONSTRUCTION	3
MATERIALS	3
LABELING & INSTRUCTIONS	3
HEADGEAR LABELING	3
PROJECTILE LABELING	3
SAMPLES FOR TESTING	4
CONDITIONING	4
IMPACT TEST INSTRUMENTS AND EQUIPMENT	4
APPENDIX 1	8
JANUARY, 2002 MODIFICATIONS/REVISIONS	9
APRIL, 2003 MODIFICATIONS/REVISIONS	9
JANUARY, 2004 MODIFICATIONS/REVISIONS	9
FEBRUARY, 2005 MODIFICATIONS/REVISIONS	9
DECEMBER, 2005 MODIFICATIONS/REVISIONS	9
JANUARY, 2008 MODIFICATIONS/REVISIONS	9
JULY, 2009 MODIFICATIONS/REVISIONS	9
AUGUST 2011 MODIFICATIONS/REVISIONS	9
MAY 2012 MODIFICATIONS/REVISIONS	10
JUNE 2012 MODIFICATIONS/REVISIONS	10
DECEMBER 2012 MODIFICATIONS/REVISIONS	10
JUNE 2013 MODIFICATIONS/REVISIONS	10
DECEMBER 2013 MODIFICATIONS/REVISIONS	10
OCTOBER 2014 MODIFICATIONS/REVISIONS	10
MARCH 2015 MODIFICATIONS/REVISIONS	10
MAY 2015 MODIFICATIONS/REVISIONS	10
MAY 2015 ADDITIONAL MODIFICATIONS/REVISIONS	10
JUNE 2015 MODIFICATIONS/REVISIONS	11
JANUARY 2017 MODIFICATIONS/REVISIONS	11
FEBRUARY 2018 MODIFICATIONS/REVISIONS	11
JANUARY 2019 MODIFICATIONS/REVISIONS	11

1. Scope

- 1.1. This standard test method describes laboratory equipment and basic requirements pertinent to projectile impact testing of protective headgear or certain projectiles. Deviations, additions or both, to this test method will be specified, as required, in individual standard performance specifications.
- 1.2. ***All testing and requirements of this standard specification must be in accordance with NOCSAE DOC 001 where appropriate.***
- 1.3. This standard test method is limited to use with products associated with specific NOCSAE standards.
- 1.4. *This standard does not purport to address all of the safety problems, if any, associated with its use. It is the responsibility of the user of this standard to establish appropriate safety and health practices plus determine the applicability of regulatory limitations prior to use.*

2. Referenced Documents

- 2.1. NOCSAE DOC (ND) 001: *Standard Test Method and Equipment Used in Evaluating the Performance Characteristics of Headgear/Equipment*
- 2.2. ASTM F 1888: *Standard test method for compression-displacement of baseballs and softballs*
- 2.3. ASTM F 1887: *Standard test method for measuring the coefficient of restitution (COR) of baseballs and softballs*

3. Specific Terminology

- 3.1. See Section 3, NOCSAE DOC 001.
- 3.2. Descriptions of terms specific to this standard
 - 3.2.1. Baseball: Any such ball defined by the rules of the game as published by the sports' governing bodies.
 - 3.2.2. Mass: The weight of the ball as measured by a scale. Reported in ounces (oz.).
 - 3.2.3. Compression-Displacement Load (C-D): The reaction force or load due to a specified displacement of compression of the test specimen. Reported in units of pounds force (lbs.) accompanied by either the percentage of sample displacement or a fixed displacement value. For example 25% C-D equals 200 lbs.
 - 3.2.4. Compression-Displacement Curve: The relationship between compression and displacement often viewed by graphing the values of compression versus displacement.

- 3.2.5. Coefficient of Restitution (COR): A measure of energy loss during rebound. Calculated as rebound velocity divided by in-bound velocity. Values range from 0 (complete energy loss) to 1 (no energy loss). Reported as a ratio of velocities and thus has no units.
- 3.2.6. Displacement: The reduction in a specimen's diameter measured as the change in distance between two flat plates. Reported in units of inches (in) or percentage of original sample.
- 3.2.7. Projectile: Any hurled or struck body that is used as an integral component of the sport being played that has the potential of contacting a player of that sport.
- 3.2.8. Linear Bearing Table: A sliding table top fitted with the necessary supports to position a headform at various angles and rotations in order to facilitate projectile impacts at the designated locations. This table may be mounted to a separate device that allows for rapid elevation adjustments.
- 3.2.9. Critical sizes are defined as follows:
 - 3.2.9.1. The helmet's "Stetson" size that corresponds to the correct headform's "Stetson" size.
 - 3.2.9.2. The thinnest padding configuration for a particular helmet shell on the smallest headform designated for the selling size range for that particular shell.

4. Significance and Use

- 4.1. The purpose of this test method is to provide reliable and repeatable measurements for the evaluation of various types of protective headgear and/or projectiles. This test method is based on pass/fail criteria only for SI and within specified tolerances for other measures.
- 4.2. A passing headgear/equipment is able to withstand the impact at an acceptable SI and meets all other requirements of the Performance Specifications when tested in accordance with this test method. In order to certify a model, all sizes of that model required to be tested by each specification must meet all aspects of the standard.
- 4.3. A passing projectile is able to meet the mass, circumference, COR and C-D values for a given level to be certified to that level and meets all other requirements of the Performance Specifications when tested in accordance with this test method.
- 4.4. This test method must be used in conjunction with the specific individual standard performance specifications relative to a specific activity.

5. Summary of Test Method

- 5.1. Headgear: A headgear is positioned on a headform that is rigidly mounted on a linear bearing table to achieve a somewhat realistic post impact situation. The projectile is propelled at the headgear such that the impact velocity is within 3% of the specified velocity. At impact, the instantaneous resultant acceleration is measured by a triaxial accelerometer and the Severity Index calculated.

- 5.2. Projectiles: A projectile is propelled to strike a steel or ash block that is rigidly mounted to substantial vertical surface. A projectile is propelled at the block such that the impact velocity is within 3% of the specified velocity. Projectiles may also be subjected to other mechanical testing.

6. Certification

- 6.1. See Section 6, NOCSAE DOC 001

7. Construction

- 7.1. General: Headgear shall be constructed to reduce the acceleration of the wearer's head, and to remain on the wearer's head, during impact. Optional devices fitted to the headgear shall be designed so that they are unlikely to cause injury during use.
- 7.2. Projectiles shall be constructed without sharp edges.
- 7.3. Headgear must survive all test protocols substantially intact and ready for use.
- 7.4. Projectiles must survive all test protocols substantially intact and ready for use.
- 7.5. Projections in Headgear: Any internal rigid projections that may contact the wearer's head during impact shall be covered so as to reduce the likelihood of injury.

8. Materials

- 8.1. See Section 8, NOCSAE DOC 001.
- 8.2. Materials used in projectiles shall be such that any wear and tear from normal use will not result in loss of physical properties as measured in this test method.

9. Labeling & Instructions

- 9.1. Headgear Labeling: See Section 9, NOCSAE DOC 001
- 9.2. Projectile Labeling
 - 9.2.1. Each projectile shall be permanently and legibly labeled in a manner such that the following information can be easily read:
 - 9.2.1.1. Name of Manufacturer
 - 9.2.1.2. Model Designation
 - 9.2.1.3. The following logos, "NOCSAE®", "  ".
The logos may appear in any order but cannot give credence to some other criteria/specification.
 - 9.2.2. Packaging for projectiles shall be permanently and legibly labeled in a manner such that the following information can be easily read:
 - 9.2.2.1. Month and year of manufacture

- 9.2.2.2. A label that warns the user that no projectile can prevent all injuries at any velocity and for added protection against projectiles, a helmet and face/eye protector should be worn.
- 9.2.3. Warnings: Each projectile shall have appropriate warning information as called for in the individual performance specification.
- 9.2.4. Date of Manufacture: The month and year of manufacture shall be permanently and legibly labeled on either the projectile or the packaging or both.

10. Samples for Testing

- 10.1. Headgear shall be tested complete, in the condition as offered for sale or use unless specified otherwise in an individual Performance Specification.
- 10.2. Projectiles shall be tested in the condition as offered for sale or use unless specified otherwise in an individual Performance Specification.
- 10.3. Helmets shall be tested on each size headform that they fit. See Section 20, NOCSAE DOC 001.
- 10.4. Headgear/projectiles used for testing must be selected in a random manner.
- 10.5. See Section 11, NOCSAE DOC 001.

11. Conditioning

- 11.1. See Section 12, NOCSAE DOC 001.
- 11.2. Low Temperature: Expose product to conditioned temperature of $32^{\circ}\text{F} + 0^{\circ}\text{F}$, $- 3^{\circ}\text{F}$ ($0^{\circ}\text{C} + 0^{\circ}\text{C}$ or $- 1^{\circ}\text{C}$) for at least four hours.

12. Test Instruments and Equipment

- 12.1. Projectile launching device capable of propelling the specified projectile to the specified velocity within 3% and having a targeting device that allows impacts within a $\frac{1}{4}$ in. radius 24 inches from the muzzle or the point at which the projectile is first in "free flight." For COR testing the device shall be able to return the projectile to the point of launch at the muzzle within the variation specified.
- 12.2. A Strike Plate that is either a 2 ± 0.01 in. (5.08 ± 0.025 cm) thick steel plate or a 4 ± 0.01 (10.2 ± 0.025 cm) thick northern white ash wood block with a moisture content between 10-15%, that is at least 24.0 in. (61 cm) square, mounted flush to a massive rigid wall of cinder block or concrete, minimally 8 in. (20.3 cm) thick as perpendicular to the line of flight of the ball as possible such that a baseball propelled towards the strike plate will rebound to within a 6 in. circular target located 2 feet from the strike plate.
- 12.3. Electronic speed monitors capable of measuring the inbound and rebound velocity of a ball when it is propelled at the strike plate through two gates at speeds of 60.0 ± 2.0 mph. The first gate is mounted $24" \pm 0.125"$ from the strike plate and the second gate is mounted $12" \pm 0.125"$ from the first gate. A "proof of accuracy" method (such as a paper target or high speed video) is required to determine that the trajectory of the ball does not deviate more than 6 in. while traveling through the light gates before and after impact

- with the strike plate before and after each series of tests.
- 12.4. The entire moving assembly of the linear bearing table and the supporting headform apparatus that may be in motion during or after an impact shall not exceed 5.7 kg \pm 0.5 kg. This aggregate weight does not include the headform or the headform coupler.
 - 12.5. Recommended Air Cannon Assembly Including Linear Bearing Table Assembly (See Figures 1 and 2).
 - 12.6. See Section 15, NOCSAE DOC 001.
 - 12.7. See Appendix 1 to verify headform response prior to impact testing. Headforms used for all specifications that require the recording of Severity Index to be reported and/or maintained below some set level shall perform in accordance with Appendix 1.
 - 12.8. Projectiles used as part of the test method as a means of delivering an impact to an item subject to testing, shall meet the mechanical requirements for mass, C-D, and size for that specific projectile as specified in the appropriate Performance Specifications for the item subject to testing.
 - 12.8.1. In addition to the requirements above, the response for softballs shall be verified prior to use in impact testing by impact onto a medium (blue) headform in accordance with the procedures in steps 1, 3, and 5 of Appendix 1. Softballs shall meet the requirements of Step 5 prior to use in any impact testing requiring the recording of Severity Index. Softballs used for impact testing must have flat seams.
 - 12.9. A device for measuring the weight of an object with a mass between 10 grams and at least 500 grams with a resolution of 0.1 g and displaying results in oz.
 - 12.10. A compression device capable of producing a compressive force of at least 500 lbs. with a resolution of at least 0.05 lbs. The device must have enough clearance to allow compression of an object that is in excess of 5 inches in diameter at a variable rate from at least 0.5 to 2 inches per minute. The platens applying load to the ball shall be flat.

This standard is subject to revision at any time by the responsible technical authority and must be reviewed every five years and if not revised either reapproved or withdrawn. Your comments are invited either for revision, modification or creation of additional standards and should be addressed to NOCSAE's Executive Director. Check the web at www.nocsae.org to obtain the latest version of a standard.

This standard is copyrighted by NOCSAE 11020 King Street, Suite 215 Overland Park, Kansas 66210 USA. Copies may be obtained from the NOCSAE web site at www.nocsae.org

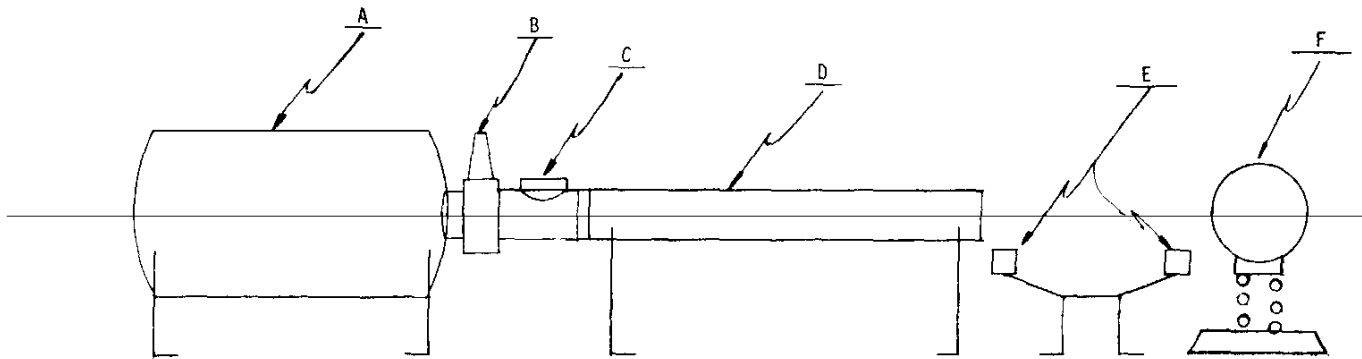

This is an exemplary system; any system that provides the required test parameters is acceptable.

- A = air reservoir
- B = air solenoid
- C = loading breech
- D = interchangeable barrel
- E = velocity measurement sensors
- F = head form—fully adjustable 3 axis and rotation

FIG. 1 Ball Propelling Device

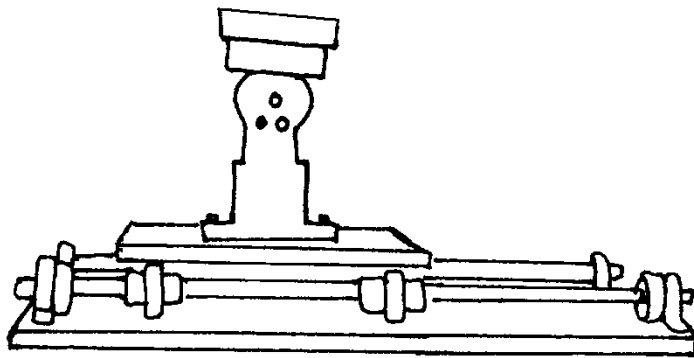

Linear Bearing Table - Figure 2

Appendix 1

Procedure for Verification of NOCSAE Headforms Projectile Response

Prior to commencing the verification, carefully inspect all equipment to ensure your lab's mechanical system is in proper working order.

Verification Protocol:

Step 1: The headform shall be calibrated as described in NOCSAE DOC 001.

Step 2: Obtain a Rawlings Major League Baseball, with the following properties:

- weight: 142 - 146 grams
- circumference: 9.00 - 9.25 inches
- compression - deflection: 200 - 300 lbs
- constructed as specified by Major League Baseball

Note: The above mechanical properties shall be determined as required in NOCSAE DOC 027. Failure to verify ball properties prior to headform verification will result in suspect data.

Step 3: Insure that the projectile impacts the headform in the standard right side as described in Section 19, NOCSAE DOC 001, lower speeds will cause the projectile to drop during its free flight. Use the table below to determine the appropriate velocity ranges for impacts with the major league baseball. Softball impacts shall be conducted at an appropriate velocity range to insure compliance with step 5 below. Record the values and perform a review.

Small (Red) Headform	Medium (Blue) Headform	Large (Green) Headform
30 ± 1 mph	34 ± 1 mph	36 ± 1 mph
32 ± 1 mph	36 ± 1 mph	38 ± 1 mph
34 ± 1 mph	38 ± 1 mph	40 ± 1 mph
36 ± 1 mph	40 ± 1 mph	42 ± 1 mph
38 ± 1 mph	42 ± 1 mph	44 ± 1 mph
40 ± 1 mph	44 ± 1 mph	46 ± 1 mph
42 ± 1 mph	46 ± 1 mph	48 ± 1 mph

Step 4: Determine if your headforms have the appropriate response.

- Small headforms shall pass through 1200 SI between 32 - 40mph
- Medium headforms shall pass through 1200 SI between 36 - 44mph
- Large headforms shall pass through 1200 SI between 38 - 46mph.

Step 5: Determine that the softball causes the Medium headform to pass through 1200 SI at a velocity of no greater than 30 MPH. Note that the Medium headform used for this step must have the response specified in step 4 when impacted with a Major League Baseball.

If you have any questions as to how to perform this procedure, contact Southern Impact Research Center at info@soimpact.com.

JANUARY 2002 MODIFICATIONS/REVISIONS

- Simplified document references within document.

APRIL 2003 MODIFICATIONS/REVISIONS

- Section 12.1, added polo ball to description of device capable of propelling balls.
- Section 9, updated labeling instructions to include placement of date on product and updated the requirements for projectile labeling.
- Section 2.3, added references to ASTM test methods F 1887 and F 1888.

JANUARY 2004 MODIFICATIONS/REVISIONS

- Added additional terminology related to NOCSAE DOC 027
- Added additional verbiage related to ND 027
- Added equipment relative to ND 027
- Changed seal/logo/logo document to allow use of the manufacturers name in place of the word, "Manufacturer".

FEBRUARY 2005 MODIFICATIONS/REVISIONS

- Modified section 9.5 to clarify fitting/positioning instructions.

DECEMBER 2005 MODIFICATIONS/REVISIONS

- Added Lacrosse ball and baseball NOCSAE logos.

JANUARY 2008 MODIFICATIONS/REVISIONS

- Modified Section 9 placement of date code

JULY 2009 MODIFICATIONS/REVISIONS

- Added Section 12.6.1
- Added Appendix 1

AUGUST 2011 MODIFICATIONS/REVISIONS

- **REVISION:** Added wording associated with the certifier's / re-certifier's responsibility in adequately demonstrating compliance to the standards and use of the NOCSAE logo.
- Added Section 6 and updated Section 9 to coincide with the requirements in ND 001 for clarity.
- Clarified section 12.6.1 to require verified headform use in testing
- Added requirement to verify baseball/softball response prior to use
- Clarified and added to Appendix 1 requirement for response of headforms/balls

MAY 2012 MODIFICATIONS/REVISIONS

- Clarified Sample Determination in section 10
- Moved low temp environment specification to section 11 for clarity
- Updated section 6.1, added section 6.1.2.1, modified 6.1.3

JUNE 2012 MODIFICATIONS/REVISIONS

- **REVISION:** Added headform selection requirement to section 10

DECEMBER 2012 MODIFICATIONS/REVISIONS

- Added eye protector to packaging warning section 9.8.2.2

JUNE 2013 MODIFICATIONS/REVISIONS

- Modified effective date

DECEMBER 2013 MODIFICATIONS/REVISIONS

- Modified section 6 certification to refer to section 6 in NOCSAE DOC 001

OCTOBER 2014 MODIFICATIONS/REVISIONS

- Updated title name of NOCSAE DOC 001
- Added SEI Certification NOCSAE Logo to Section 9, “Labels and Warnings”

MARCH 2015 MODIFICATIONS/REVISIONS

- Changed effective date
- Updated NOCSAE seal/logo artwork
- Changed projectile NOCSAE SEI logo marking requirement

MAY 2015 MODIFICATIONS/REVISIONS

- Corrected typo in section 11.2 misidentified temperature scale

MAY 2015 ADDITIONAL MODIFICATIONS/REVISIONS

- Changed reference to ‘logo’ and/or ‘seal’ to ‘seal/logo’
- Removed text box on NOCSAE seal/logo artwork, Appendix 2
- Removed NOCSAE seal/logo artwork for ND 055

JUNE 2015 MODIFICATIONS/REVISIONS

- Updated NOCSAE seal/logo artwork

JANUARY 2017 MODIFICATIONS/REVISIONS

- Removed labeling language in section 9.1 and added reference to NOCSAE DOC 001.
- Clarified SEI/NOCSAE logo requirements, section 9.2.1
- Removed Appendix 2

FEBRUARY 2018 MODIFICATIONS/REVISIONS

- REVISION: Appendix 1: Changed ball mass requirement from 140 - 145 grams to 142 - 146 grams
- Removed materials language from Section 8.1 and added reference to NOCSAE DOC 001.
- Updated formatting

JANUARY 2019 MODIFICATIONS/REVISIONS

- Modified projectile labeling requirements to allow date of manufacture on the projectile or the packaging.