

**STANDARD TEST METHOD
AND PERFORMANCE
SPECIFICATION FOR
NEWLY MANUFACTURED
FOOTBALL PLAYERS HAND COVERINGS**

NOCSAE DOC (ND) 019 – 10m15a

Prepared By



**NATIONAL OPERATING COMMITTEE
ON STANDARDS FOR ATHLETIC EQUIPMENT**

Modified June 2015
Effective December 31, 2015

Table of Contents

Scope.....	1
Reference Documents.....	1
Terminology	1
Test Sample Size	2
Sample Preparation.....	2
Certification	3
Test Equipment.....	3
Test Methods	3
Peel Adhesion Test.....	3
Friction Test.....	4
Performance Requirements.....	5
Reports	5
Labels and Warnings.....	5
FEBRUARY, 2010 MODIFICATIONS/REVISIONS	9
JUNE, 2010 MODIFICATIONS/REVISIONS	9
MAY, 2012 MODIFICATIONS/REVISIONS	9
MAY, 2013 MODIFICATIONS/REVISIONS	9
SEPTEMBER, 2014 MODIFICATIONS/REVISIONS	9
MARCH, 2015 MODIFICATIONS/REVISIONS.....	9
JUNE, 2015 MODIFICATIONS/REVISIONS.....	9

1. Scope

- 1.1. This standard specification establishes performance requirements for the friction and adhesion properties of new football player's hand coverings (gloves, hand pads, etc.) as supplied by manufacturers. This standard test method and performance specification is specifically created to limit the level of stick/tackiness of hand coverings to limit the potential aid these devices may have in handling/catching the ball. The requirements of this standard shall be subject to Level 1 compliance criteria unless otherwise stated herein.
- 1.2. *This standard does not purport to address all of the safety problems, if any, associated with its use. It is the responsibility of the user of this standard to establish appropriate safety and health practices and determine the applicability of regulatory limitations prior to use.*

2. Reference Documents

- 2.1. STANDARD TEST METHOD AND EQUIPMENT USED IN EVALUATING THE PERFORMANCE CHARACTERISTICS OF HEADGEAR/EQUIPMENT, NOCSAE DOC.001
- 2.2. ASTM D1894-90 STANDARD TEST METHOD FOR STATIC AND KINETIC COEFFICIENTS OF FRICTION OF PLASTIC FILM AND SHEETING.
- 2.3. ASTM D3330 STANDARD TEST METHODS FOR PEEL ADHESION OF PRESSURE SENSITIVE TAPE AT 180 DEGREE ANGLE.

3. Terminology

- 3.1. Add-ons: Anything supplied with or recommended by any literature, including point of purchase materials and/or markings and packaging that accompanies for sale gloves/hand pads. Add-ons may be of any material including liquids, sprays, etc.
- 3.2. Ambient: Normal laboratory environment, 72° F, ± 5° F (22° C, ± 2° C).
- 3.3. Component: Any piece, part, or device that accompanies the hand covering or is part of the hand covering as offered for sale and may become separated (by design) from other hand covering components, or must be assembled or attached by the user.
- 3.4. Glass, Pattern #62¹: Pebbled glass surface in a size suitable to fit a friction table with enough travel to allow friction testing of hand covering material to 2 inches minimum. Prior to testing each sample, the glass surface shall be cleaned with 91% isopropyl alcohol and allowed to dry. A visual examination will be made to ensure no lint, dust, or other visible material is detected.
- 3.5. Glove: A covering for the hand having separate sections for each finger. Pads worn on the hand, but not having, separate sections encircling at least part of any finger are not gloves. The thumb is not considered a finger for

¹ The pattern #62 glass is available from SIRC.

this section.

- 3.6. Hand: That portion of the upper extremity distal to the Radial Ulnar Joint.
- 3.7. Hand Pad: A covering for the hand which is not a glove, and does not have any webbing between fingers or thumb but does cover some portion of the wearer's hand.
- 3.8. Hand Covering: Any materials that cover the hand.
- 3.9. Webbing: Excess material designed to increase surface area between fingers or finger and thumb.
- 3.10. Legible: May be easily read at a distance of not less than 18 inches by an individual with 20/20 corrected vision.
- 3.11. Model: See NOCSAE DOC.001 Section 3.
- 3.12. Permanent (Label): A label, or similar markings, that cannot be readily (1), removed without leaving a trace of its previous existence (2), erased or (3), smudged to the point that it is illegible. If it **requires** chemical or mechanical means such as the use of solvents, abrasives, grinding, etc., to remove a label or marking, than that label or marking is acceptable.
- 3.13. Static coefficient of friction (SCOF): The peak force to get the sled moving from rest divided by the sled and sample weight.
- 3.14. Transfer: Material(s) including but not limited to the base material of a hand covering, dyes, colorants, additives etc., that remain on the pattern #62 glass after a test.
- 3.15. Visible: Can be seen by a person with corrected or natural 20/20 vision from a distance of 18".

4. Test Sample Size

- 4.1. See Sections 6 and 11, NOCSAE DOC.001, for QC/QA/QA protocol testing.
- 4.2. For any standalone test report; at least 5 hand coverings per model must be tested. A minimum of three pairs of the largest size per model must be submitted.
- 4.3. Copies of any point of purchase materials.

5. Sample Preparation.

- 5.1. Hand covering sets new, and as offered for sale to the public, shall be submitted for this test.
- 5.2. Hand coverings selected for testing must be selected in a random manner.
- 5.3. If there are any add-ons recommended or supplied with the hand coverings the hand coverings must be tested both with and without add-ons. In this

case additional samples shall be provided.

6. Certification.

- 6.1. See section 6 of NOCSAE DOC 001 for certification requirements.

7. Test Equipment

- 7.1. A load cell, scale or other device for measuring pull force with an accuracy of +/- 0.5% of full scale reading, for load cells or scales with a capacity of 20lbs or less.
- 7.2. A tensile/compression tester or other device that can apply a force at a constant rate within 3% of any rate specified in the standard.
- 7.3. Weighted footprint for application of the correct load in psi to test samples as in figure 1.
- 7.4. Glove last (sled) as in figure 2 with retention screw and swivel. The combined weight of which shall be 200g +/- 10.

8. Test Methods

- 8.1. Peel Adhesion Test

Samples of hand covering material are tested for adhesion to pattern #62 glass as follows:

- 8.1.1. Sample preparation: Hand covering material from the palm or the actual finger of a hand covering shall be removed and trimmed to size based on weight but must be at least 1" wide. The sample shall be without seams. The sample shall be cleaned prior to testing by gently wiping with a low lint cloth (such as Kimwipes®) dampened with 91% isopropyl alcohol. The sample shall be allowed to completely air dry so that there is no visible evidence of alcohol present prior to testing. Samples with add-ons or components shall be tested both with and without add-ons and/or components. Such add-ons and or components will be applied as directed by literature that accompanies either the hand covering or add-on or both. The hand covering material contact area to weighted footprint must be at least 2 square inches and shall weigh no more than 4 grams.
- 8.1.2. Pattern #62 glass that has been cleaned and dry prior to use in any test will be put in contact with the hand covering material exterior or side intended to contact the ball when worn. The Pattern #62 glass is placed on the smooth solid surface of a natural stone surface plate with its pebbled surface facing up. The hand covering material exterior side shall be placed on the pebbled glass surface and weighted using the weighted footprint at the rate of at least 2 psi for a minimum of one hour. The contact area of the weighted footprint shall lie within the boundaries of the hand covering material with a section of wax paper isolating the hand covering material from the

weighted footprint. The weight is removed and within 5 seconds the glass is slowly lifted and smoothly rotated 180 degrees. The glass shall be held steady a minimum of 10 inches above the surface of the table in the inverted position for a maximum of 90 seconds.

8.2. Friction Test

Samples of hand covering material are tested for friction against pattern #62 glass as follows:

- 8.2.1. Sample preparation: Hand covering material from the palm or the actual finger of a glove is removed and affixed to the last (see figure 2). The sample shall span the flat bottom edge of the last without interference from seams. The sample is clamped to the last with the retention screw provided or in such a way that the material is not pre-stretched and remains on the last during the test.
- 8.2.2. A last may be fabricated to facilitate testing of a sample which cannot be tested on the last defined in figure 2 (see figure 3). The fabricated last must be no less than 0.50" in width, have a leading edge with a radius of 0.25" and be of sufficient mass so that the last and sample material has a combined mass of 200 +/-10 grams.
- 8.2.3. Where, in the opinion of the technician, the positioning of the hand covering material is incorrect and would yield erroneous test results, the technician **must** adjust the hand material or fabricate an appropriate last to obtain a more reasonable test configuration.
- 8.2.4. If the hand covering material cannot be positioned so that the sample spans the entire flat bottom edge without interference from any seams on the lasts specified in this specification, then that hand material cannot be certified to this standard.
- 8.2.5. The sample shall be cleaned prior to testing by gently wiping with a low lint cloth (such as Kimwipes[®]) dampened with 91% isopropyl alcohol. The sample shall be allowed to completely air dry so that there is no visible evidence of alcohol present prior to testing. Samples with add-ons or components shall be tested both with and without add-ons and/or components. Such add-ons and or components will be applied as directed by literature that accompanies either the hand covering or add-on or both.
- 8.2.6. Pattern #62 glass, cleaned and dry prior to use, at least 50% wider than the hand covering material sample contact surface (bottom of last) is clamped to a horizontal platform with its pebbled surface facing upward. The test specimen attached to the friction sled (last with a combined weight of 200 +/-10 grams) is pulled across the pebbled surface of the pattern #62 glass at a rate of 50 +/-2 mm/min. The peak pull force is recorded.
- 8.2.7. Each hand covering sample shall be tested three times across the pebbled glass surface with 75 ±15 seconds between each successive pull test.

- 8.2.8. The SCOF for each pull test is determined by calculation. The average of the three pulls shall be taken to determine the SCOF value for the hand covering.

9. Performance Requirements

- 9.1. When tested in accordance with section 8.1., the hand covering material must freely fall from the pebbled glass surface within 90 seconds after the glass is rotated a full 180 degrees.
- 9.2. When tested in accordance with Section 8.2 the SCOF must be 4.5 or less.
- 9.3. When tested in accordance with Sections 8.1 or 8.2 there shall be no visible transfer of material from the hand covering material to pattern #62 glass.

10. Reports

- 10.1. Maintain complete test records for all testing. The records can be stored on paper, electronically or photographically. The test report shall contain the following information.
 - 10.1.1. Name and location of the test laboratory.
 - 10.1.2. Name of Laboratory Technician.
 - 10.1.3. Model and size of each glove/hand covering material tested, name of manufacturer and date of manufacture.
 - 10.1.4. Observed laboratory temperatures.
 - 10.1.5. Peel adhesion test results shall be reported as either pass or fail, comments to include trials, results of each trial.
 - 10.1.6. Friction test results. Report the peak force for each of the three pulls, the average force of the three pulls and record calculated SCOF for each sample tested. Note pass or fail.
 - 10.1.7. Record if any add on, or component was used during the testing.

11. Labels and Warnings

- 11.1. Each glove/hand pad shall be permanently and legibly labeled or marked in a manner such that the following information can be easily read and is not obscured in any manner.
 - 11.1.1. Name of Manufacturer or a Logo or recognizable mark that is registered and/or trademarked to the manufacturer.
 - 11.1.2. Model Designation.
 - 11.1.3. Size.

11.1.4. Month and Year of Manufacture.

11.1.5. A permanent, exact replica of this seal must appear legibly on the exterior wrist opening so as to be accessible, without removal of the glove/hand pad, to the referee for inspection. If the label is stitched to the glove it must be positioned/positionable such that this information is visible and legible.



NOTE: You must have an executed, valid license agreement with NOCSAE to use any of the NOCSAE logos at any time. NOCSAE, the NOCSAE seals/logos, and the National Operating Committee on Standards for Athletic Equipment are registered marks and the exclusive property of the Committee. Use of the marks in any manner is prohibited without prior written permission of the NOCSAE Board of Directors. This seal maybe scaled so long that it remains legible.

11.2. Packaging and/or instructional literature for gloves/hand pad shall be permanently and legibly marked in a manner such that the following information can be easily read.

11.2.1. Information that warns the user that the glove/hand pad can be altered by contact with common substances and that this alteration may or may not be visible to the user. Such alteration may effect NOCSAE certification. This information should also list any recommended cleaning agents or procedures, or both that can be used without altering glove performance.

This standard is subject to revision at any time by the responsible technical authority and must be reviewed every five years and if not revised either reapproved or withdrawn. Your comments are invited either for revision, modification or creation of additional standards and should be addressed to NOCSAE's Executive Director. Check the web at www.nocsae.org to obtain the latest version of a standard.

This standard is copyrighted by NOCSAE 11020 King Street, Suite 215 Overland Park, Kansas 66210 USA. Copies may be obtained from the NOCSAE web site at www.nocsae.org

Pressure Plate

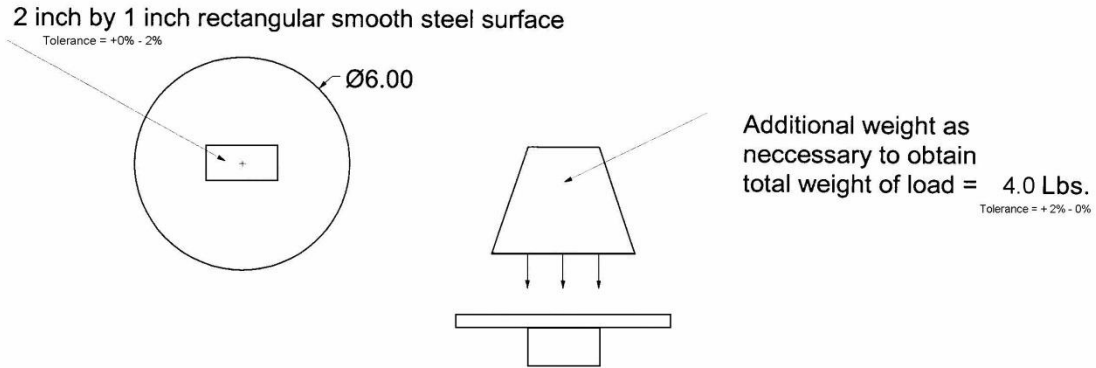

Figure 1

Glove Last

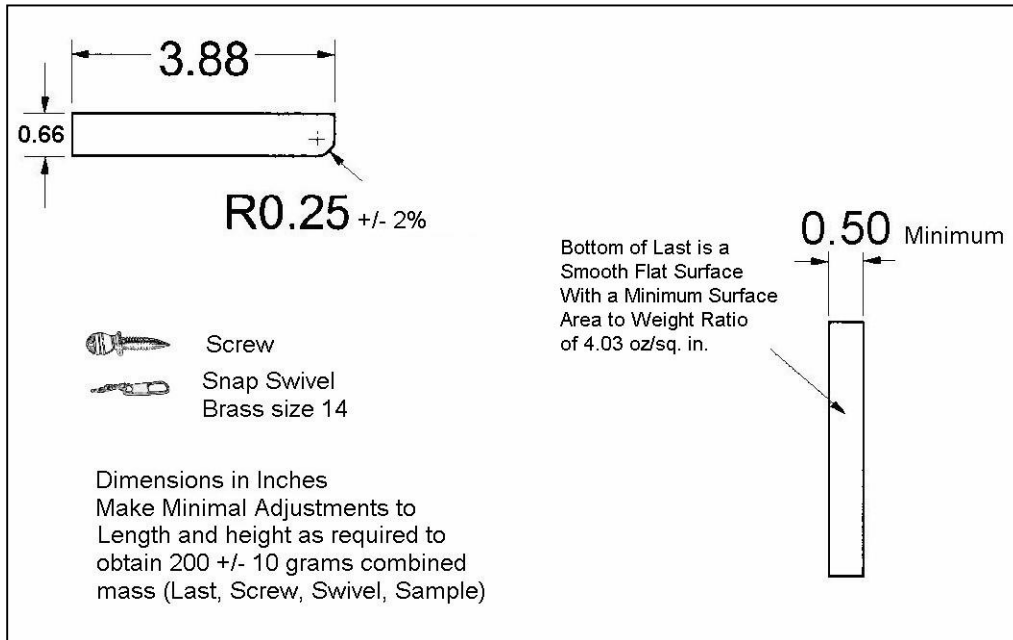

Figure 2

Hand Pad Last

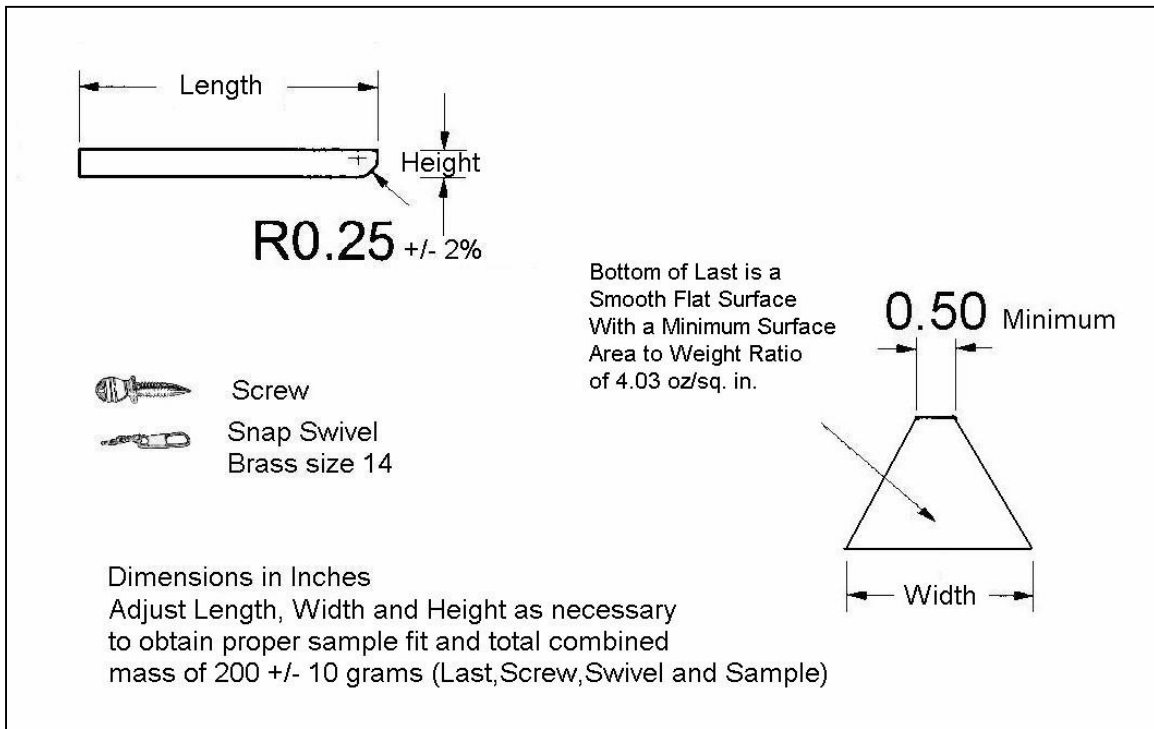

Figure 3

FEBRUARY, 2010 MODIFICATIONS/REVISIONS

- Changed description from Gloves to Hand Coverings
- Added definitions for hand, hand pad, hand covering and webbing
- Updated Friction Test procedure for testing hand pads, added three pull test requirement, added erroneous results statement
- Added Hand Pad Last Figure 3
- Added tolerances and minimum required dimensions to equipment drawings

JUNE, 2010 MODIFICATIONS/REVISIONS

- **Revision-** Added sample cleaning requirement. Changed weighted footprint PSI requirement. Changed length of time weighted footprint is placed on sample. Changed dwell time allowed for peel adhesion test. Changed SCOF requirement.

MAY, 2012 MODIFICATIONS/REVISIONS

- Clarified section 4 for standalone test report
- Moved requirements to section 5 from section 4 for clarity

MAY, 2013 MODIFICATIONS/REVISIONS

- Corrected typo for Last weight

SEPTEMBER, 2014 MODIFICATIONS/REVISIONS

- Removed color requirement for Model Section 3.11

OCTOBER, 2014 MODIFICATIONS/REVISIONS

- Updated document to include level of compliance requirements.
- Added SEI Certification NOCSAE Logo to Section 9, "Labels and Warnings"

MARCH 2015, MODIFICATIONS/REVISIONS

- Clarified statement in section 8 regarding weighted footprint contact to glove material

JUNE 2015 MODIFICATIONS/REVISIONS

- Updated NOCSAE seal/logo artwork