

**STANDARD PERFORMANCE
SPECIFICATION FOR
NEWLY MANUFACTURED
LACROSSE HELMETS
WITH FACEGUARD**

NOCSAE DOC (ND) 041- 15m17

Prepared By



**NATIONAL OPERATING COMMITTEE
ON STANDARDS FOR ATHLETIC EQUIPMENT**

Effective: January 31, 2018

TABLE OF CONTENTS

Scope	1
Referenced Documents	1
Test Sample Size	1
Helmet Preparation.....	1
Testing Sequence	2
Helmet Stability/Retention Testing.....	2
Impact Attenuation Tests.....	2
Helmet Drop Tests.....	2
Labels and Warnings.....	4
IMPACT LOCATIONS – HELMET DROPS.....	7
Figure 3.....	7
Figure 4.....	8
JULY, 2004 MODIFICATIONS/REVISIONS	9
AUGUST, 2004 MODIFICATIONS/REVISIONS	9
JUNE, 2005 MODIFICATIONS/REVISIONS.....	9
JANUARY, 2008 MODIFICATIONS/REVISIONS	9
FEBRUARY 2011, MODIFICATIONS/REVISIONS.....	9
MAY 2012 MODIFICATIONS/REVISIONS	9
OCTOBER 2014 MODIFICATIONS/REVISIONS	9
JANUARY 2015 MODIFICATIONS/REVISIONS	9
JUNE 2015 MODIFICATIONS/REVISIONS.....	10
JANUARY 2017 MODIFICATIONS/REVISIONS	10

1. Scope

- 1.1. This standard specification establishes performance requirements for new lacrosse headgear as supplied by manufacturers. Helmets are to be tested with attached compatible faceguard. Faceguards must be, or have been, tested to and comply with NOCSAE 045 on the same helmet model as presented for testing. The requirements of this standard shall be subject to Level 3 compliance criteria unless otherwise stated herein.
- 1.2. **All testing and requirements of this standard specification must be in accordance with NOCSAE DOC.001 and NOCSAE DOC.021 except where modified herein.**
- 1.3. *This standard does not purport to address all of the safety problems, if any, associated with its use. It is the responsibility of the user of this standard to establish appropriate safety and health practices and determine the applicability of regulatory limitations prior to use.*

2. Referenced Documents

- 2.1. STANDARD TEST METHOD AND EQUIPMENT USED IN EVALUATING THE PERFORMANCE CHARACTERISTICS OF HEADGEAR/EQUIPMENT, NOCSAE DOC.001
- 2.2. STANDARD PERFORMANCE SPECIFICATION FOR NEWLY MANUFACTURED LACROSSE FACE PROTECTORS NOCSAE DOC 045

3. Test Sample Size

- 3.1. See Sections 6 and 11, NOCSAE DOC.001, for QC/QA protocol testing.
- 3.2. For any standalone test report; at least one (1) set of four (4) helmets of each model in each critical size must be tested. Two (2) will be tested at ambient; two (2) will be tested at high temperature.

4. Helmet Preparation

- 4.1. See Section 10, NOCSAE DOC.001
- 4.2. Faceguards - During all testing the helmets must be tested with a compatible faceguard (mask) that has been certified to meet the NOCSAE standard attached.
- 4.3. Helmets of a given model with a size smaller than 6 5/8 **may** not fit the smallest NOCSAE headform. In that event, testing of that size is waived so long as the other sizes of that model have been tested and meet all requirements.
- 4.4. To obtain a reasonable fit (as determined by the test technician) for testing purposes, helmets larger than size 7 5/8 **may** require "shim" pads to be inserted between the largest NOCSAE headform and the interior of the helmet, opposite from the impact site.

- 4.5. High Temperature: Expose product to conditioned temperature of $100^{\circ}\text{F} \pm 3^{\circ}\text{F}$ ($39^{\circ} \pm 1^{\circ}\text{C}$) for at least four hours and a maximum of twenty-four (24) hours.

NOTE: When performing conditioned environment temperature testing, the first impact shall occur between the 1st and 2nd minute after removing the sample from the conditioning environment. The second impact shall occur 75 seconds (± 15 sec) after the first impact, etc. If the sample cannot be tested within these time constraints, the sample must be returned to the conditioning environment for a minimum of 3 minutes for each minute the sample was out of the conditioning environment. Conditioning must be complete before testing can resume on that sample.

5. Testing Sequence

- 5.1. The helmet stability/retention test described below shall be performed prior to any of the impact tests.

6. Helmet Stability/Retention Testing (Chin cup)

- 6.1. A helmet stability (roll-off) stand is depicted in Figure 1 and shall include a guide rod and stop anvil (see Figure 2) similar to that used in the Retention System test, minus the strap fixture (two rods). This guide apparatus shall weigh 2.5 ± 0.5 lb (1.13 ± 0.23 kg).
- 6.2. A cable and attached hook connect the guide rod to the far edge of the helmet. The cable and hook shall weigh less than 0.45 lb (0.2 kg). The hook shall engage no less than $\frac{1}{2}$ linear inches (12.7 mm) of the helmet edge.
- 6.3. The ambient helmet shall be affixed to the correct size NOCSAE headform in accordance with the manufacturer's instructions with only the primary retention system adjusted as described in those instructions. This helmet shall then be subjected to a positional stability test by allowing a 9 lb (4.08 kg) drop mass to pull on the back edge of the helmet when dropped from a height of 2.78 feet (0.85 m). During this test the headform will be canted downwards at a 45° angle from vertical and facing the floor. The helmet shall remain on the headform upon the completion of this test.

7. Impact Attenuation Tests

7.1. Helmet Drop Tests

- 7.1.1. Impact locations are described in Section 19, NOCSAE DOC.001.
- 7.1.2. Impacts shall be conducted on the Test MEP pad (see Section 15.2.2, NOCSAE DOC.001).
- 7.1.3. Helmets shall be impacted in accordance with Table 1 below and as depicted in Figure 3 (also see Figure 4). The ambient conditioned helmets are impacted first to determine which shall be the high temperature tested location.

7.1.4. At least two (2) locations, not to exceed four (4) locations, are to be selected for the high temperature impacts. This is accomplished by determining which of the 60 inch ambient temperature locations tested yielded the two highest severity indexes on each of the ambient samples. Those locations shall be tested at high temperature on each of the samples subjected to high temperature testing.

7.1.5. The random location chosen cannot be less than 1 inch (25 mm) from any standard impact location.

TABLE 1

LOCATION - DROP velocities – ft/s (m/s)
(All drop velocities must be within +3% -0%)

	FRONT	RIGHT SIDE	RIGHT F. BOSS	RIGHT R. BOSS	REAR	TOP	RANDOM
Ambient Temperature	11.34 (3.46)	11.34 (3.46)	11.34 (3.46)	11.34 (3.46)	11.34 (3.46)	11.34 (3.46)	11.34 (3.46)
	16.04 (4.88)	16.04 (4.88)	16.04 (4.88)	16.04 (4.88)	16.04 (4.88)	16.04 (4.88)	16.04 (4.88)
	17.94 (5.46)	17.94 (5.46)	17.94 (5.46)	17.94 (5.46)	17.94 (5.46)	17.94 (5.46)	17.94 (5.46)
High * Temperature	17.94 (5.46)	17.94 (5.46)	17.94 (5.46)	17.94 (5.46)	17.94 (5.46)	17.94 (5.46)	17.94 (5.46)

NOTE: Impacts at ambient must be conducted in sequence from the lowest drop velocity through the highest.

* The location to be impacted for the high temperature impacts varies and depends upon the results of the ambient temperature impacts completed first (see 8.2.4. and 8.2.5 above). New (non-impacted) helmets are to be used for the high temperature impacts and each high temp sample shall receive impacts to at least two, but no more than 4, locations.

8. Test Requirements

8.1. The peak severity index of any impact shall not exceed 1200 SI.

8.2. The 11.34 ft/s impacts designated in Table 1 must not exceed 300 SI*.

8.3. Helmet repositioning during testing is anticipated. Any structural changes or other changes that take place during impact testing which result in un-restorable, loosening of the fit (see Section 20, NOCSAE DOC.001) shall be cause for failure. In the case of helmets “shimmed” as per section 4.3, the replacement or repositioning of shims is allowed.

8.4. A passing helmet model is able to withstand all impacts at an acceptable SI and meets all other requirements when tested in accordance with this performance specification.

♦ This requirement shall be subject to Level 2 compliance criteria.

9. Labels and Warnings

9.1. See Section 9, NOCSAE DOC.001 and Section 9, NOCSAE DOC.021.

9.2. Each helmet shall have permanently affixed to the exterior of the shell a clearly legible statement which can be easily read without removal of any decal tape, other temporary material or permanent part, which contains language which effectively communicates to the purchaser and user the following information, using the same or similar language:

WARNING

DO NOT USE THIS HELMET IF THE SHELL IS CRACKED OR DEFORMED; OR IF THE INTERIOR PADDING IS DETERIORATED. SEVERE HEAD OR NECK INJURY, INCLUDING PARALYSIS OR DEATH MAY OCCUR TO YOU DESPITE USING THIS HELMET. NO HELMET CAN PREVENT ALL HEAD INJURIES OR ANY NECK INJURIES A PLAYER MIGHT RECEIVE WHILE PARTICIPATING IN LACROSSE



10.3 A permanent, replica of this seal must appear legibly on the exterior of the helmet shell. (See note below)

NOTE: You must have an executed, valid license agreement with NOCSAE to use any of the NOCSAE logos at any time. NOCSAE, the NOCSAE seals/logos, and the National Operating Committee on Standards for Athletic Equipment are registered marks and the exclusive property of the Committee. Use of the marks in any manner is prohibited without prior written permission of the NOCSAE Board of Directors.

This standard is subject to revision at any time by the responsible technical authority and must be reviewed every five years and if not revised either reapproved or withdrawn. Your comments are invited either for revision, modification or creation of additional standards and should be addressed to NOCSAE's Executive Director. Check the web at www.nocsa.org to obtain the latest version of a standard.

This standard is copyrighted by NOCSAE 11020 King Street, Suite 215 Overland Park, Kansas 66210 USA. Copies may be obtained from the NOCSAE web site at www.nocsa.org

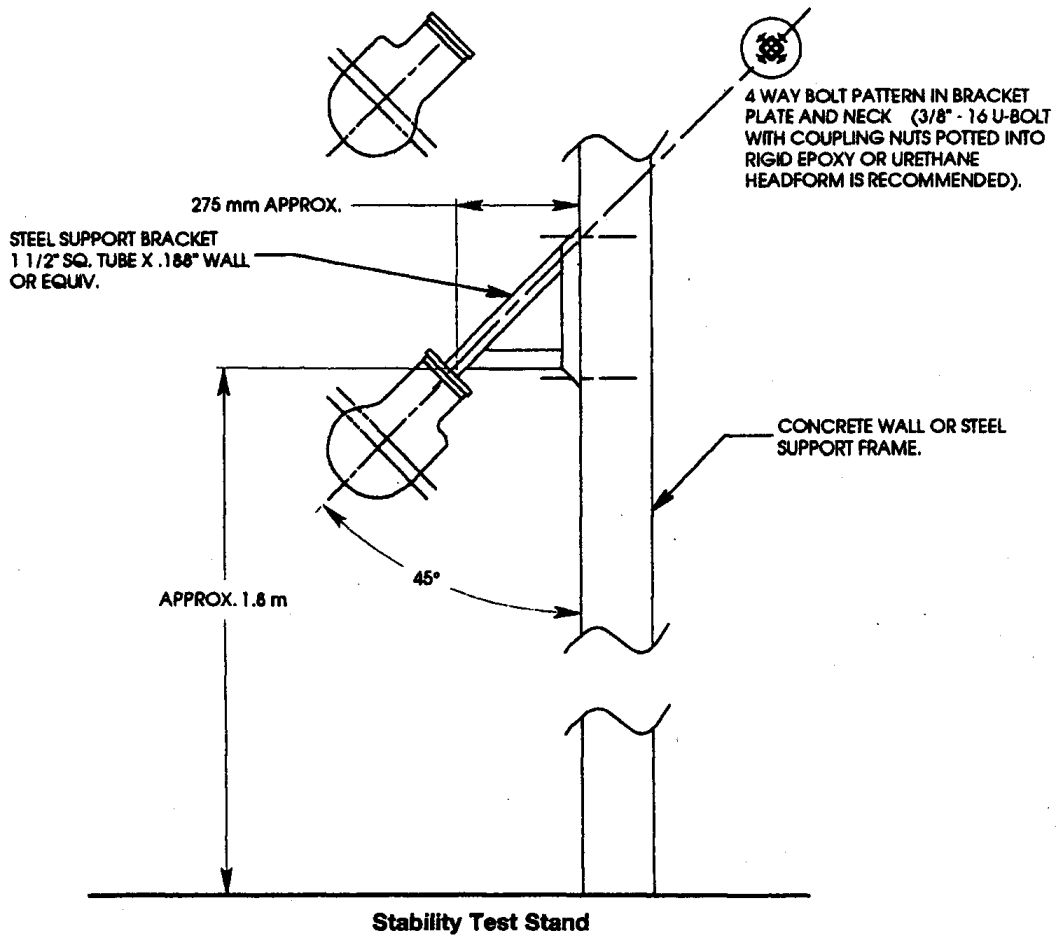

Figure 1

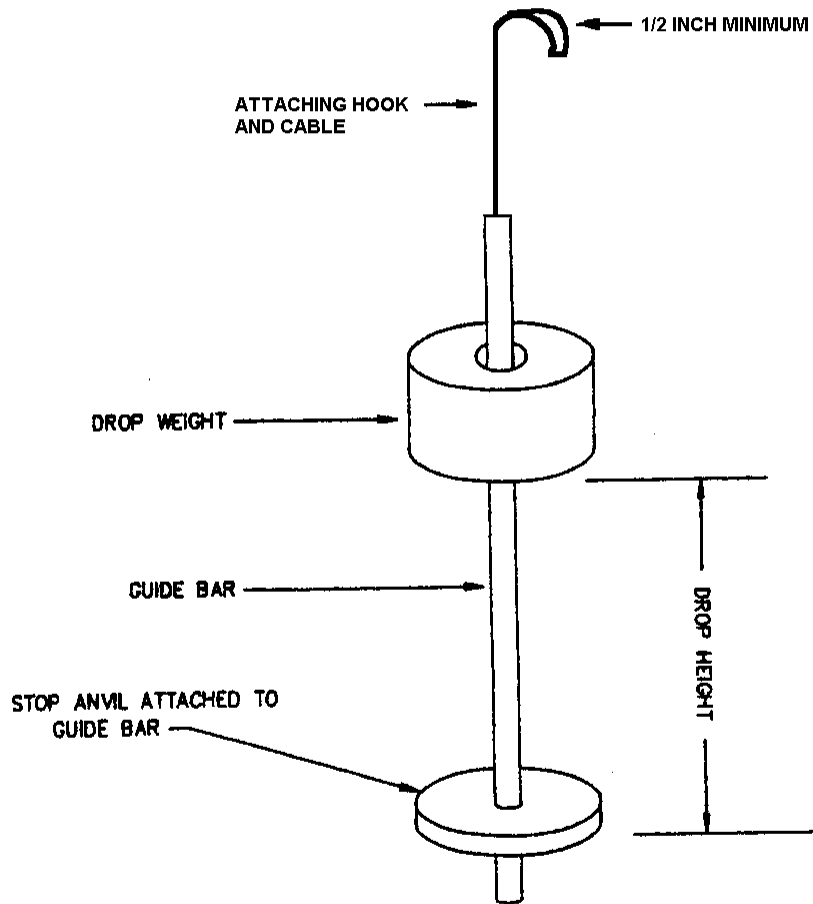

Figure 2

IMPACT LOCATIONS – HELMET DROPS



Front



Side



Right Front Boss



Right Rear Boss



Rear

Figure 3



Top

IMPACT LOCATIONS

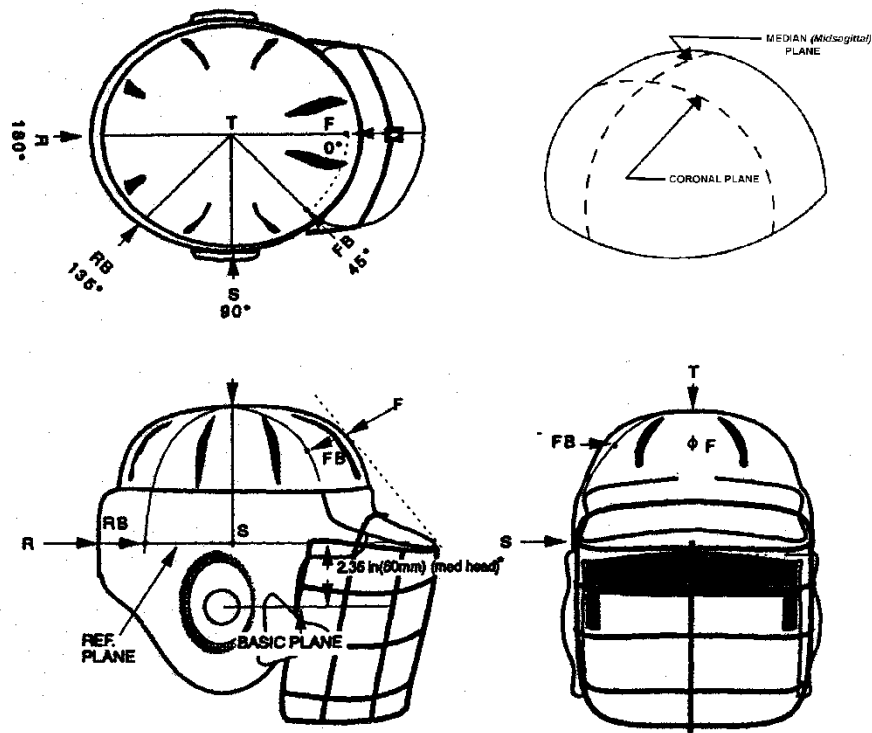

* For the small headform the REFERENCE PLANE is 2.16 inches above the BASIC PLANE. For the large headform the REFERENCE PLANE is 2.48 inches above the BASIC PLANE.

The random location may be selected from any point within the allowed impact area but not closer than 1 inch (25 mm) from the edge of the helmet nor less than 1 inch (25 mm) from any previous impact.

Random locations chosen must allow the rotator assembly to be locked in the position selected.

Impact Area - for a helmet that is to be tested on the medium headform*, the impact area must include all locations on the headform above the BASIC PLANE rearward of a location 2 inches (51 mm) forward of where the BASIC PLANE intersects with the CORONAL PLANE and any point on or above the REFERENCE PLANE in front of that same intersection.

* For the small headform use 1.75 inches (44 mm) and for the large headform use 2.25 inches (57 mm).

Figure 4

JULY, 2004 MODIFICATIONS/REVISIONS

- Modified section 4.2 to clarify required number of helmets per test (set).
- Modified section 8.2.5 to clarify that each high temperature sample gets impacted at each of the highest SI locations based on the ambient test. This can be no less than two nor more than four locations.
- Modified Note associated with Table 1 to clarify high temp impact requirements.

AUGUST, 2004 MODIFICATIONS/REVISIONS

- Modified Scope
- Added NOCSAE 045 as a referenced document

JUNE, 2005 MODIFICATIONS/REVISIONS

- **Revised** impact schedule Table 1 to eliminate the 60-inch impacts in the Random Location.
- **Revised** projectile impact requirement, eliminated section 8.3 Helmet Projectile Tests, Figure 5 and references to Lacrosse Ball Impacts.
- Modified Note section 9.3 to clarify need for license agreement
- Modified NOCSAE contact information

JANUARY, 2008 MODIFICATIONS/REVISIONS

- Modified section 8.2.2, corrected reference to face protector

FEBRUARY 2011, MODIFICATIONS/REVISIONS

- **REVISION-** Change drop heights to drop velocities. Moved test requirements to section 10. Clarified test requirements.

MAY 2012 MODIFICATIONS/REVISIONS

- Moved requirements in section "Specific Terminology" to 'Helmet Preparation", Deleted section.
- Clarified section 3 for standalone test report
- Moved requirements to section 4 from section 3 for clarity

OCTOBER 2014 MODIFICATIONS/REVISIONS

- Updated document to include level of compliance requirements.
- Added Date specification becomes effective
- Updated title name of NOCSAE DOC. 001
- Added SEI Certification NOCSAE Logo to Section 9, "Labels and Warnings"

JANUARY 2015 MODIFICATIONS/REVISIONS

- **REVISION-** Removed requirement to alter standard impact locations to avoid impact with visor and/or faceguard. Added requirement to impact random locations at 17.94 ft/s.
- Added photos of impact locations

JUNE 2015 MODIFICATIONS/REVISIONS

- Updated NOCSAE seal/logo artwork

JANUARY 2017 MODIFICATIONS/REVISIONS

- Modified text accompanying Figure 4 describing random impact locations.