

**STANDARD PNEUMATIC RAM TEST METHOD AND
EQUIPMENT USED IN EVALUATING THE
PERFORMANCE CHARACTERISTICS OF
PROTECTIVE HEADGEAR AND
FACE GUARDS**

NOCSAE DOC (ND) 081-14m15

Prepared By



**NATIONAL OPERATING COMMITTEE
ON STANDARDS FOR ATHLETIC EQUIPMENT**

Effective no earlier than January 2016

TABLE OF CONTENTS

SCOPE 1

SIGNIFICANCE AND USE..... 2

SUMMARY OF TEST METHOD 2

SYSTEM CHECK..... 3

IMPACT LOCATIONS..... 3

IMPACT ATTENUATION TESTS..... 5

FIGURE 1 6

FIGURE 2 7

FIGURE 3 8

MAY 2015 MODIFICATIONS/REVISIONS..... 9

1. Scope

- 1.1 This standard test method describes laboratory equipment and basic requirements pertinent to pneumatic ram testing of protective headgear with face guards. The concept of the pneumatic ram is to deliver an impact to a helmeted, instrumented, headform on a Hybrid III neck that is free to move post impact. This test method has been designed to subject the headgear to both centric and non-centric impacts while capturing both linear and rotational acceleration. It is believed that compliance with this test method will lead to improved headgear performance. Deviations to this test method will be specified in individual standard performance specifications.
- 1.2 ***All testing and requirements of this standard specification must be in accordance with NOCSAE DOC.001 where appropriate.***
- 1.3 This standard test method is limited to use with products associated with specific NOCSAE standards.
- 1.4 *This standard does not purport to address all of the safety problems, if any, associated with its use. It is the responsibility of the user of this standard to establish appropriate safety and health practices plus determine the applicability of regulatory limitations prior to use.*

2. Referenced Documents

- 2.1. NOCSAE DOC ND 001: *Standard Test Method and Equipment Used in Evaluating the Performance Characteristics of Headgear/Equipment*
- 2.2. NOCSAE DOC ND 101: *Equipment Calibration Procedures.*

3. Specific Terminology

- 3.1. Descriptions of terms specific to this standard
 - 3.1.1. Pneumatic Ram: A device that is capable of delivering an impact to the target by moving along a straight line towards the target. The impactor shall be capable of delivering impacts in the range of 3.0 – 9.0 m/s and shall be in guided free flight at the time of impact.
 - 3.1.2. Impactor Rod: The portion of the pneumatic ram system that holds the impactor head and is propelled towards the headform.
 - 3.1.3. Impactor Head: Attached to the end of the impactor rod and contacts the helmet. It is constructed of polyurethane disc in between engineered aluminum pieces. The face of the impactor head must have a convex face conforming to the radius in figure 1. The MEP disc shall have a thickness of 1.5 inches and a Shore A hardness of 43 +/- 2.
 - 3.1.4. Impactor: Impactor rod and impactor head including any additional components required for braking that does not exceed 15.5 kg +/- 3%
 - 3.1.5. Rotational Acceleration: A measure of impact severity with respect to the peak acceleration experienced by the headform measured in radians per second squared (rad/s²). Acceptable rotational acceleration levels measured during impact cannot exceed the limit specified in the appropriate NOCSAE standard performance specification.

- 3.1.6. Linear Bearing Table: A sliding table top fitted with the necessary supports to position a headform at various angles and rotations in order to facilitate impacts at the designated locations. This table may be mounted to a separate device that allows for rapid elevation adjustments.
- 3.1.7. Guided Free Flight: Condition in which the impactor is being neither actively propelled nor braked while being guided to the target.

4. Significance and Use

- 4.1. The purpose of this test method is to provide reliable and repeatable measurements for the evaluation of various types of protective headgear. This test method is based on pass/fail criteria for Severity Index (SI), Rotational Acceleration (rad/s^2), and within specified tolerances for other measures.
- 4.2. A passing headgear is able to withstand the impact at an acceptable SI, rad/s^2 , and meets all other requirements of the Performance Specifications when tested in accordance with this test method.
- 4.3. This test method must be used in conjunction with the specific individual standard performance specifications relative to a specific activity.

5. Summary of Test Method

- 5.1. A headgear is positioned on a headform that is mounted onto a 50th percentile Hybrid III neck assembly which is rigidly mounted to a linear bearing table to achieve post impact kinematics. The impactor is propelled at the headgear such that the velocity is within 2% of the specified level when measured over a distance no more than two inches. Impact must occur within one inch of velocity capture. At impact, the resultant peak linear acceleration, Severity Index, and resultant peak rotational acceleration shall be captured.

6. Test Instruments and Equipment

- 6.1. A machine capable of propelling the impactor to the specified velocity +/- 2%. The machine shall have a targeting device able to locate the initial point of contact of the center of the impactor head with the headgear within a 1/4" radius within 1" of passing through the velocity measuring device. The machine must allow the impactor to make contact with the headgear while in guided free flight for all standard and random impact locations.
- 6.2. An impactor rod that has an outer diameter of nominal 2 inches and inner diameter of nominal 1.25 inches and a weight of 29.25 lbs (13.3 kg) +/- 3%
- 6.3. Impactor Head: Weight shall be 5.05 lbs (2.3 kg) +/- 3%
- 6.4. Hybrid III 50th percentile male neck assembly with titanium nodding joint assembly available from Humanetics Innovative Solutions, Inc. The neck cable shall be tightened to 12 in-lb as specified by the Hybrid III user's manual with a calibrated torque wrench.
- 6.5. A linear bearing table that is capable of providing some post impact motion with a weight of 34.65 lbs (15.75 kg) +/- 5%.
- 6.6. Headform pedestal assembly that allows rotation in both the transverse (Z axis rotation)

and sagittal (Y axis rotation) planes relative to the headform. The transverse rotation point must be positioned beneath the sagittal rotation point.

- 6.7. Recommended Pneumatic Ram including Linear Bearing Table Assembly (See Figure 2)
- 6.8. Electronic velocity monitor capable of measuring the in-bound velocity of the impactor head within 1 inch of initial contact with the headgear.
- 6.9. Modified NOCSAE headforms designed to be used with 9 accelerometer systems in sizes small, medium, and large
- 6.10. Single axis piezoresistive accelerometers: Endevco 7264-2000B or equivalent
- 6.11. DC amplifier: Endevco Model 136 or equivalent
- 6.12. Impact recording software: BioDAQ version 6.0 available from Biokinetics and Associates. Other computer-based systems may be used if equivalence to the BioDAQ 6.0 software can be demonstrated.

7. System Check

- 7.1. A system check must be performed just prior to testing and the results maintained as part of the certification test data
- 7.2. A system check must be performed upon the completion of a product testing session and the results maintained as part of the certification test data.
- 7.3. Any variation between 7.1 and 7.2 must be 7% or less.

8. Impact Locations

Note: The starting position should be with the nose of the headform pointing towards the ram and all measurements and angles listed in tables 8.1, 8.2, and 8.3 are relative to this position. The positive direction for α angle is tilting forward towards the ram, and the positive direction for β angle is clockwise. The Z and Y axis measurements are relative to the headform.

8.1. Small Headform Impact Locations

| Impact Location | α | β | Z axis relative to basic plane | Y axis |
|-----------------|----------|---------|--------------------------------|------------------------------------|
| Side | 7 ° | -90 ° | +54.9 mm | on the coronal plane |
| Rear Boss NC | 7 ° | -90 ° | +54.9 mm | 58.7 mm posterior coronal plane |
| Rear Boss CG | 7 ° | -135 ° | +54.9 mm | 74.1 mm posterior to coronal plane |
| Rear | 7 ° | -180 ° | +54.9 mm | on the midsagittal plane |
| Front Boss | 15 ° | -60 ° | +67 mm | 51.4 mm anterior to coronal plane |
| Front | 15 ° | 0 ° | +71.4 mm | on the midsagittal plane |

8.2. Medium Headform Impact Locations

| Impact Location | α | β | Z axis relative to basic plane | Y axis |
|-----------------|----------|---------|--------------------------------|----------------------------------|
| Side | 7 ° | -90 ° | +60 mm | on the coronal plane |
| Rear Boss NC | 7 ° | -90 ° | +60 mm | 64 mm posterior coronal plane |
| Rear Boss CG | 7 ° | -135 ° | +60 mm | 81 mm posterior to coronal plane |
| Rear | 7 ° | -180 ° | +60 mm | on the midsagittal plane |
| Front Boss | 15 ° | -60 ° | +73 mm | 56 mm anterior to coronal plane |
| Front | 15 ° | 0 ° | +78 mm | on the midsagittal plane |

8.3. Large Headform Impact Locations

| Impact Location | α | β | Z axis relative to basic plane | Y axis |
|-----------------|----------|---------|--------------------------------|------------------------------------|
| Side | 7 ° | -90 ° | +64 mm | on the coronal plane |
| Rear Boss NC | 7 ° | -90 ° | +64 mm | 67.2 mm posterior coronal plane |
| Rear Boss CG | 7 ° | -135 ° | +64 mm | 85.1 mm posterior to coronal plane |
| Rear | 7 ° | -180 ° | +64 mm | on the midsagittal plane |
| Front Boss | 15 ° | -60 ° | +76.7 mm | 58.8 mm anterior to coronal plane |
| Front | 15 ° | 0 ° | +81.9 mm | on the midsagittal plane |

9. Impact Attenuation Tests

- 9.1. The maximum Severity Index and peak resultant rotational acceleration cannot exceed the limits specified in the appropriate NOCSAE standard performance specification.
- 9.2. Each headgear shall be impacted in accordance with the requirements of the appropriate NOCSAE standard performance specification with respect to impact velocities, impact locations, and test conditions.
- 9.3. Random: Any point located in the impact area. The α angle shall be positioned at either 7 or 15 degrees. See Figure 3.

This standard is subject to revision at any time by the responsible technical authority and must be reviewed every five years and if not revised either reapproved or withdrawn. Your comments are invited either for revision, modification or creation of additional standards and should be addressed to NOCSAE's Executive Director. Check the web at www.nocsae.org to obtain the latest version of a standard.

This standard is copyrighted by NOCSAE 11020 King St. Suite 215, Overland Park, Kansas 66210 USA. Copies may be obtained from the NOCSAE web site at www.nocsae.org

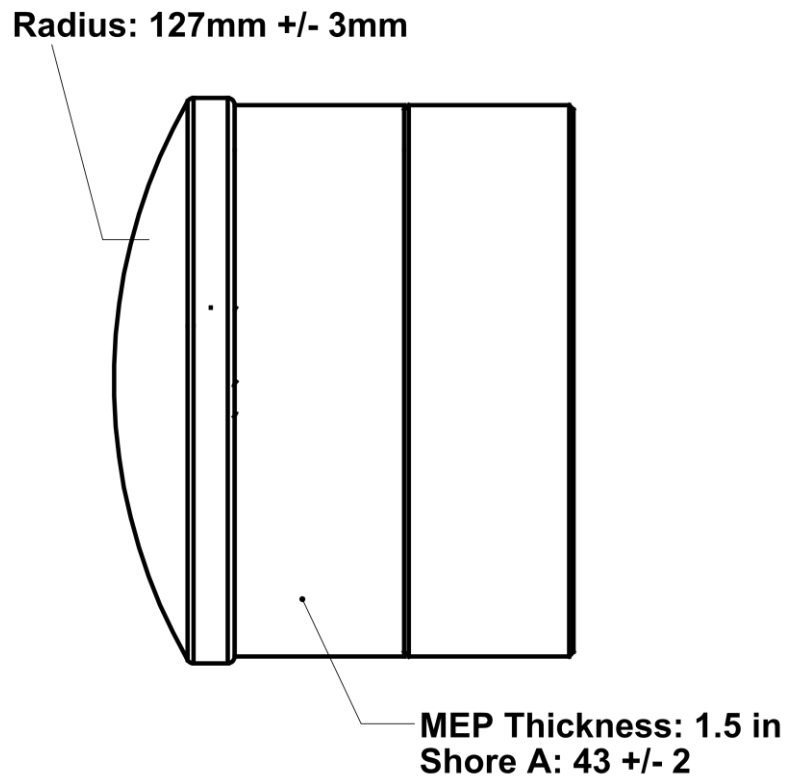

Figure 1 Pneumatic Ram Impactor Head

Linear Impactor Drawing

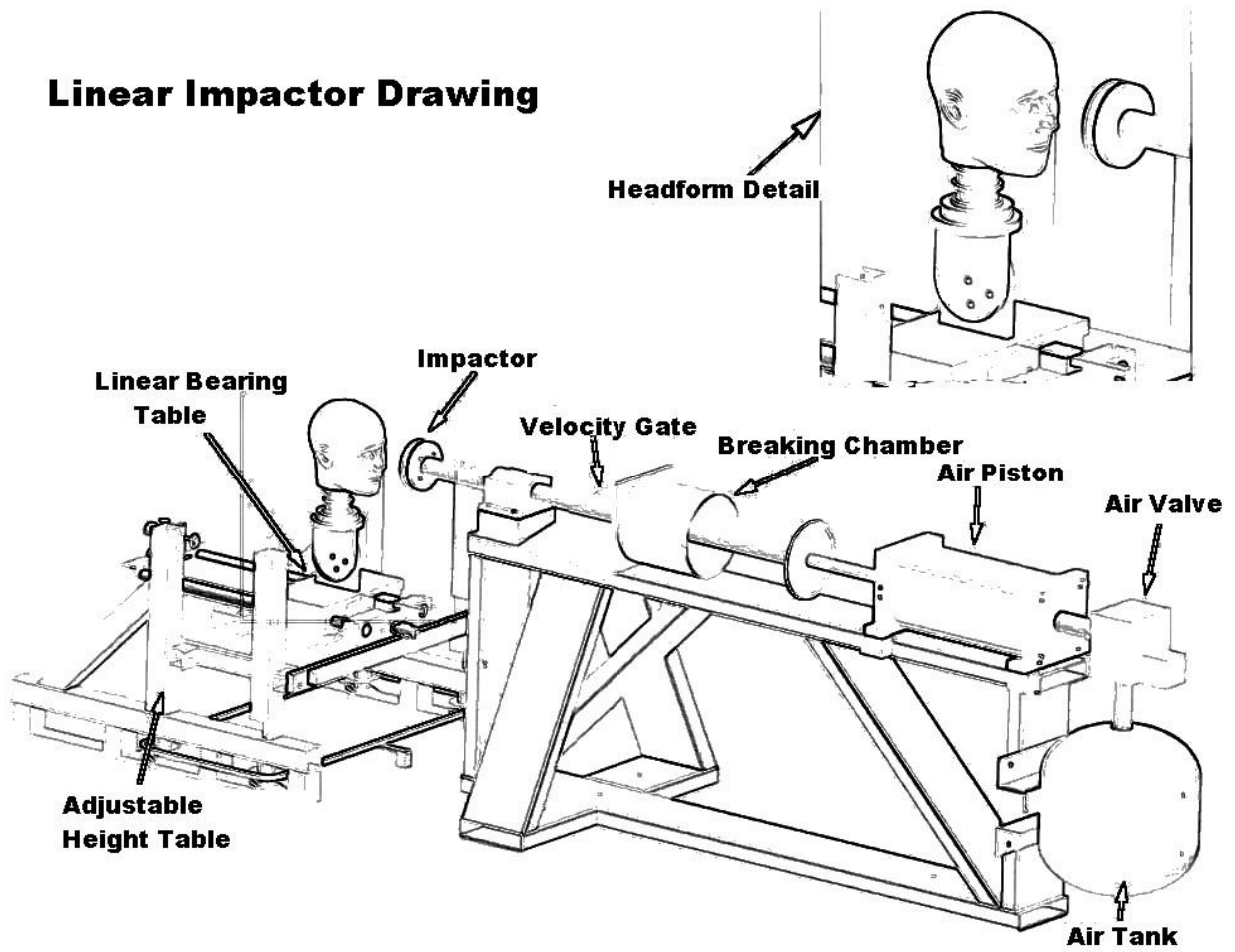
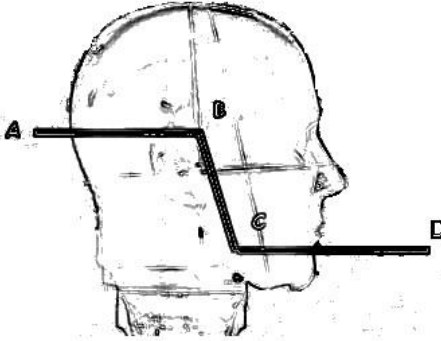

Figure 2



Impact Area – for a headgear that is to be tested on the medium headform*, the impact area must include all locations on the headform which lie on or above a line (AB) $1 \frac{3}{16}$ inches above and parallel to the BASIC PLANE posterior to the CORONAL PLANE and on or above a line (CD) $2 \frac{3}{8}$ inches below and parallel to the BASIC PLANE forward of a point $1 \frac{3}{16}$ inches anterior to the CORONAL PLANE, and forward and above line (BC) which connects these two lines. See Fig x

* For the large head forms line AB is $1 \frac{7}{16}$ " above and line CD is $2 \frac{5}{8}$ " below the basic plane. For the small headform line AB is $1 \frac{5}{16}$ " above and line CD is $2 \frac{1}{8}$ " below the basic plane.

Figure 3

MAY 2015 MODIFICATIONS/REVISIONS

- Added figures
- Added table
- Clarified numerous sections
- Added dimensions and tolerances