

**STANDARD PERFORMANCE
SPECIFICATION FOR
NEWLY MANUFACTURED
BASEBALL/SOFTBALL CATCHER'S
HELMETS WITH FACEGUARD**

NOCSAE DOC (ND) 024-10m10b

Prepared By



**NATIONAL OPERATING COMMITTEE
ON STANDARDS FOR ATHLETIC EQUIPMENT**

Modified – May 2010
Effective no earlier than June 2010

TABLE OF CONTENTS

Scope.....	1
Referenced Documents	1
Sample Size.....	1
Helmet Preparation.....	1
Impact Attenuation Tests	2
Helmets	2
Drop Tests	2
Projectile Tests	3
Faceguards	4
Labels and Warnings	5
JANUARY, 2000 MODIFICATIONS	13
APRIL, 2003 MODIFICATIONS/REVISIONS	13
JANUARY, 2004 MODIFICATIONS/REVISIONS.....	13
DECEMBER, 2005 MODIFICATIONS/REVISIONS	13
JUNE, 2006 MODIFICATIONS/REVISIONS	13
DECEMBER 2006 MODIFICATIONS/REVISIONS	13
DECEMBER 2008 MODIFICATIONS/REVISIONS	13
JANUARY 2009 MODIFICATIONS/REVISIONS.....	14
DECEMBER 2009 MODIFICATIONS/REVISIONS	14
FEBRUARY 2010 MODIFICATIONS/REVISIONS	14
MAY 2010 MODIFICATIONS/REVISIONS.....	14

1. Scope

- 1.1. This standard specification establishes performance requirements for new baseball/softball catcher's helmets with attached faceguard as supplied by manufacturers.
- 1.2. **All testing and requirements of this standard specification must be in accordance with NOCSAE DOC.001 and NOCSAE DOC.021, except where modified herein.**
- 1.3. *This standard does not purport to address all of the safety problems, if any, associated with its use. It is the responsibility of the user of this standard to establish appropriate safety and health practices and determine the applicability of regulatory limitations prior to use.*

2. Referenced Documents

- 2.1. STANDARD DROP TEST METHOD AND EQUIPMENT USED IN EVALUATING THE PERFORMANCE CHARACTERISTICS OF PROTECTIVE HEADGEAR, NOCSAE DOC.001.
- 2.2. STANDARD PROJECTILE IMPACT TEST METHOD AND EQUIPMENT USED IN EVALUATING THE PERFORMANCE CHARACTERISTICS OF PROTECTIVE HEADGEAR/PROJECTILES, NOCSAE DOC.021.

3. Sample Size

- 3.1. See Section 11, NOCSAE DOC.001.
- 3.2. At least seven (7) of each helmet model in each of the critical sizes must be tested.
 - 3.2.1. To obtain a reasonable fit (as determined by the test technician) for testing purposes, helmets larger than size 7 5/8 **may** require "shim" pads to be inserted between the largest NOCSAE headform and the interior of the helmet, opposite from the impact site.
 - 3.2.2. Helmets of a given model with a size smaller than 6 5/8 **may** not fit the smallest NOCSAE headform. In that event, testing of that size is waived so long as the other sizes of that model have been tested and meet all requirements.
- 3.3. Two of the submitted helmets shall be drop tested, two of the submitted helmets shall be impacted with a softball, one of the submitted helmets shall be impacted with a baseball and all seven of the helmets shall be used to test the attached faceguards.

4. Helmet Preparation

- 4.1. See Section 10, NOCSAE DOC.001.
- 4.2. Faceguards - During all testing the helmets must be tested with the faceguard (mask) attached and shall be mounted on a catcher's helmet according to the manufacturer's instructions.

5. Impact Attenuation Tests

5.1. General -

- 5.1.1. The peak severity index of any impact shall not exceed 1200 SI.
- 5.1.2. The softball(s) used shall weigh $5 \frac{7}{8}$ to $6 \frac{1}{8}$ ounces (166 -174 grams), have a circumference of 10.875 – 11.125 inches, have a Coefficient of Restitution of 0.43 – 0.47 and have a C-D at .25 inches of 275-375lbs.
- 5.1.3. The baseball(s) used shall weigh $5 - 5 \frac{1}{4}$ ounces (142 – 149 grams), have a circumference of 9 – 9.25 inches, have a Coefficient of Restitution of 0.5 – 0.55 and have a C-D at .25 inches of 200 – 300 lbs and be of the construction specified and used by Major League Baseball.

5.2. Helmets

5.2.1. General

- 5.2.1.1. Helmet fit must be maintained without intervention throughout the entire series of impacts. Any structural changes, or other changes that take place during the impact testing, which result in loosening the fit to the headform, shall be cause for failure. Helmet repositioning during the testing is anticipated. However, additional, un-restorable, loosening of the fit (see Section 20, NOCSAE DOC.001) is not allowed.

In the case of helmets “shimmed” as per section 3.1.1, the replacement or repositioning of shims is allowed.

- 5.2.1.2. The high temperature impacts are to be conducted on the same two (2) helmets upon which the ambient temperature tests were performed.

5.2.2. Drop Tests:

- 5.2.2.1. Impact locations are described in Section 19, NOCSAE DOC.001 and described in Figure 1.
- 5.2.2.2. Two of the submitted helmets shall be impacted in accordance with Table 1, as depicted in Figure 2 (attached), onto steel half cylinder described in Figure 3 (attached).

Note: Steel half cylinder anvil can be oriented on the anvil base in any manner the technician chooses so long as the mounting bolts can be installed. The anvil must be positioned such that the first point of contact of the helmet is at the approximate center of the steel half cylinder anvil.

TABLE 1

LOCATION - DROP HEIGHT - inches (cm)
(All drop heights must be $\pm 1/8$ ")

	RIGHT SIDE	RIGHT REAR BOSS	REAR	RANDOM
Ambient Temperature	36 (91)	36 (91)	36 (91)	36 (91)
High Temperature	36 (91)			

NOTES: The high temperature condition impacts must be done after the ambient temperature impacts.

5.2.3. Projectile Tests:

- 5.2.3.1. Impact locations are described in Section 19, NOCSAE DOC.001 and described in Figure 1.
- 5.2.3.2. The head model will be positioned with its impact site located 24in (610 mm) from the muzzle (or point at which the ball is released).
- 5.2.3.3. Two of the untested submitted sample helmets shall be impacted with a softball in accordance with Table 2 and depicted in Figure 4 (attached).

TABLE 2

LOCATION - MILES PER HOUR (m/sec)
(All speeds must be $\pm 3\%$)

	RIGHT SIDE	RIGHT REAR BOSS	REAR	RANDOM
Ambient Temperature	55 (24.6)	55 (24.6)	55 (24.6)	55 (24.6)
High Temperature	55 (24.6)			

Notes: The high temperature condition impacts must be done after the ambient temperature impacts. Impact velocity must be within 3% of the specified velocity.

- 5.2.3.4. One of the untested submitted sample helmets shall be impacted at ambient condition with a baseball in two locations. At least one of the locations shall be the location that exhibited the highest resultant Severity Index reading of the two sample helmets when impacted at ambient condition with a softball. The other location shall be selected to exploit any location on the helmet within the specified impact area (Figure 1) that may result in a failure during the impact test. The impact velocity with a baseball shall be $60 \pm 3\%$ MPH.

5.3. Faceguards

5.3.1. Projectile Tests:

- 5.3.1.1. See Section 5, NOCSAE DOC.021.
- 5.3.1.2. Five of the submitted sample helmets with attached faceguards shall be impacted with a baseball at each of these positions in accordance with Table 3 and depicted in Figure 5 (attached):
 - 5.3.1.2.1. Directly in front with the headform and helmet in an upright (vertical) position. [Barrel (line of ball travel) shall be perpendicular to the Coronal plane].
 - 5.3.1.2.2. With the headform and helmet in an upright (vertical) position and rotated away from the Midsagittal plane at a 45° angle from the direction of impact.
 - 5.3.1.2.3. Random location: The headform may be located in any manner that allows the impact point to be within the “no contact area” as defined in Figure 6, attached. Pointer or other targeting means can be set within, or to any edge of, the “no contact” area. The center of ball contact must be at the edge of, or within the “no contact” area.
- 5.3.1.3. Two of the submitted sample helmets with attached faceguards shall be impacted with a softball in two locations selected to exploit any location on the faceguard that may result in a failure during the impact test.
- 5.3.1.4. The impacts shall be aimed at each of the positions designated in 5.3.1.2. and 5.3.1.3 above according to the following:
 - 5.3.1.4.1. At least one impact shall be at the center of the widest opening in the faceguard while in the chosen position.
 - 5.3.1.4.2. At least one impact shall be aimed at the material structure of the faceguard while in the chosen position
 - 5.3.1.4.3. The random impact shall be selected to exploit any location on the faceguard that may result in a failure during the impact test.
- 5.3.1.5. No contact to the ocular area is ever permitted. Limited contact to specific areas of the headform is allowed (limited contact area). Contact occurring to the limited contact area must be restricted to those non-structural components of the headgear that are designed/intended to rest on or come in contact with the wearers face. (See Figure 6 attached).
- 5.3.1.6. Verification of ball contact - For verification of ball or protector contact with the face, cover the entire facial area (limited contact/ocular area) from the frontal bone superiorly to the mandible inferiorly with Pressure Indicator paste. Contact of either ball or protector with any part of the face will leave paste at the point of contact and proof of contact on the

headform. Inspect thoroughly both the ball and the protector to determine if they contain residue of paste. Also inspect the headform ocular area for evidence of contact.

- 5.3.1.7. The head model will be positioned with its impact site located 24in (610 mm) from the muzzle (or point at which the ball is released).

TABLE 3

**LOCATION - MILES PER HOUR (m/sec)
(All speeds must be $\pm 3\%$)**

	FRONT (90°)	AT A 45° ANGLE	RANDOM
Ambient Temperature	70 (31)	70 (31)	70 (31)
Low Temperature	70 (31)	70 (31)	N/A

Labels and Warnings

- 6.1. See Section 9, NOCSAE DOC.001 with the exception of 9.1.6 and Section 9, NOCSAE DOC.021.
- 6.2. Each helmet shall have permanently affixed to the exterior of the shell a clearly legible statement which can be easily read without removal of any decal tape, other temporary material or permanent part, which contains language which effectively communicates to the purchaser and user the following information, using the same or similar language:

WARNING

DO NOT USE THIS HELMET IF THE SHELL IS CRACKED OR DEFORMED; OR IF THE INTERIOR PADDING IS DETERIORATED. SEVERE HEAD OR NECK INJURY, INCLUDING PARALYSIS OR DEATH MAY OCCUR TO YOU DESPITE USING THIS HELMET. NO HELMET CAN PREVENT ALL HEAD INJURIES OR ANY NECK INJURIES A PLAYER MIGHT RECEIVE WHILE PARTICIPATING IN BASEBALL OR SOFTBALL

- 6.3. Each helmet that is offered to the marketplace without a faceguard shall also have permanently affixed to the exterior of the shell a clearly legible statement which can be easily read without removal of any decal tape, other temporary material or permanent part, which contains language which effectively communicates to the purchaser and user the following information, using the same or similar language

WARNING: THIS HELMET DOES NOT COMPLY WITH NOCSAE REQUIREMENTS UNLESS A FACEGUARD SPECIFICALLY LISTED BY THE MANUFACTURER IS ATTACHED.

- 6.4. A permanent, exact replica of this seal must appear legibly on the exterior of the helmet shell -

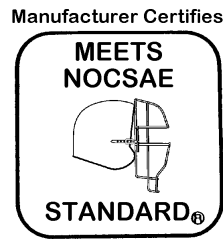

NOTE: You must have an executed, valid license agreement with NOCSAE to use any of the NOCSAE logos at any time. NOCSAE, the NOCSAE seals/logos, and the National Operating Committee on Standards for Athletic Equipment are registered marks and the exclusive property of the Committee. Use of the marks in any manner is prohibited without prior written permission of the NOCSAE Board of Directors. In place of manufacturer certifies the manufacturer may use it's own name i.e., xyz company certifies "MEETS NOCSAE STANDARD" This seal maybe scaled so long that it remains legible.

- 6.5. Any faceguard that includes a stand alone padding system shall:
- 6.5.1. Be accompanied by instructions that specify which catcher's helmets may be used with that particular faceguard. This list of helmets must be denoted by brand name and model name or number.
 - 6.5.2. Have permanently affixed to it a clearly legible statement which effectively communicates to the end user the following information, using the same or similar language:

WARNING: THIS FACEGUARD DOES NOT COMPLY WITH NOCSAE REQUIREMENTS UNLESS IT IS ATTACHED TO A HELMET SPECIFICALLY LISTED BY THE MANUFACTURER AND WHICH BEARS THE NOCSAE CATCHER'S LOGO.

This standard is subject to revision at any time by the responsible technical authority and must be reviewed every five years and if not revised either reapproved or withdrawn. Your comments are invited either for revision, modification or creation of additional standards and should be addressed to NOCSAE's Executive Director. Check the web at www.nocsae.org to obtain the latest version of a standard.

This standard is copyrighted by NOCSAE 11020 King St. Suite 215, Overland Park, Kansas 66210 USA. Copies may be obtained from the NOCSAE web site at www.nocsae.org

**CATCHER'S HELMET
IMPACT LOCATIONS**

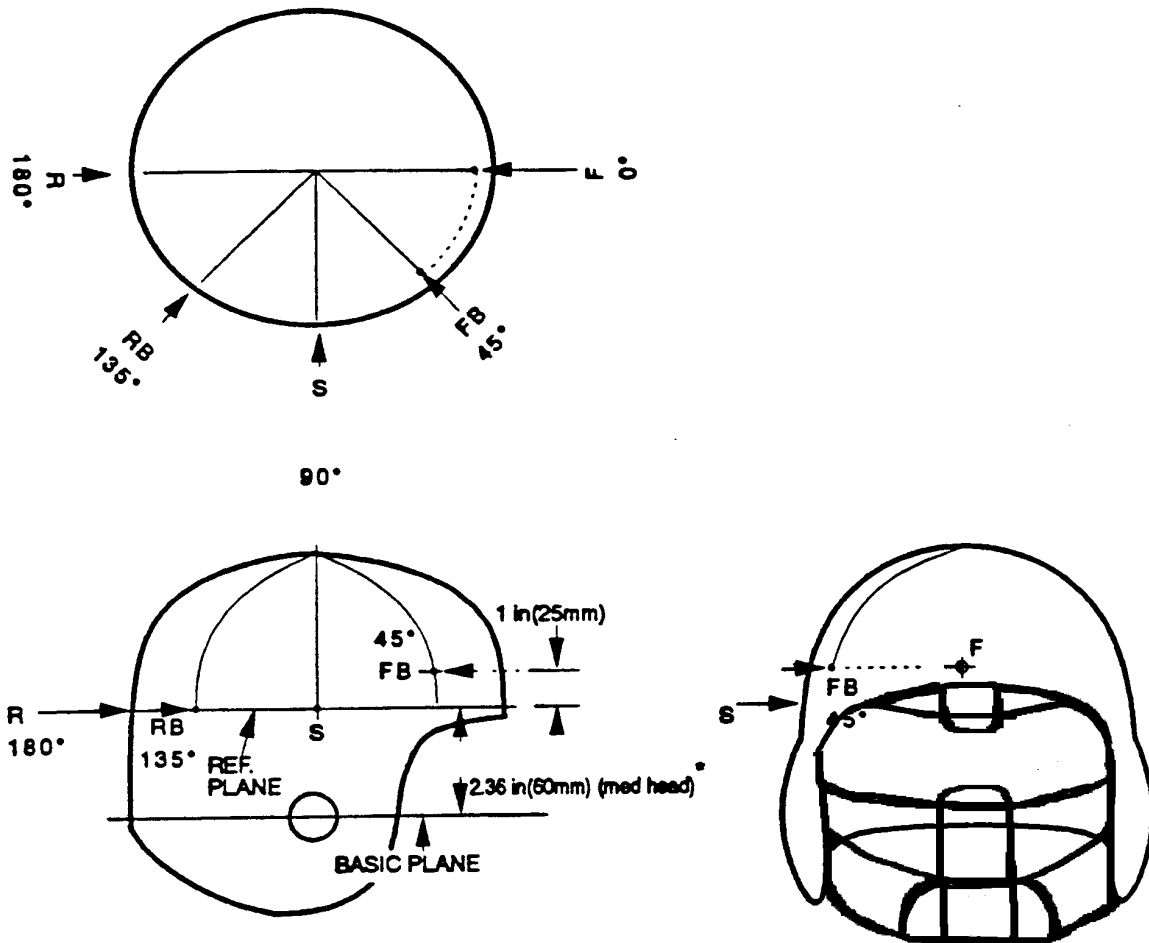

* For the small headform the REFERENCE PLANE is 2.16 inches above the BASIC PLANE.
For the large headform the REFERENCE PLANE is 2.48 inches above the BASIC PLANE.

The random location may be selected from any point within the allowed impact area but not closer than 1 inch (25 mm) from the edge of the helmet nor less than 1 inch (25 mm) from any previous impact.

Random locations chosen must allow the rotator assembly to be locked in the position selected.

Impact area- for a helmet that is to be tested on the medium headform *, the impact area must include all locations on the headform above the BASIC PLANE rearward of a location 2.5 inches (64mm) forward of where the BASIC PLANE intersects with the CORONAL PLANE and any point on or above the REFERENCE PLANE in front of that same intersection. Impact area measurements are made with the face guard in place per section 1.1.

*For the small headform use 2.25 inches (57mm) and for the large headform use 2.75 inches (70mm).

Figure 1

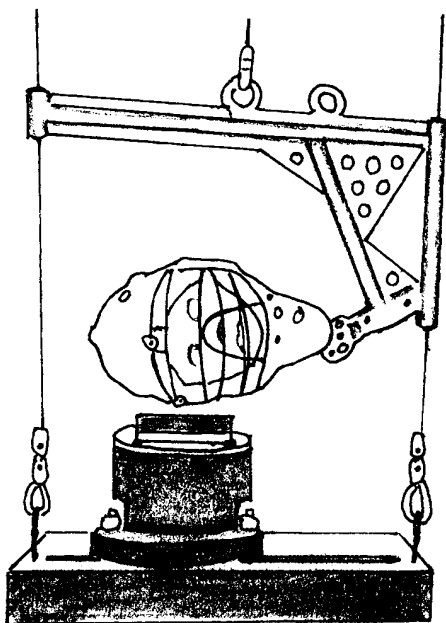

Right Side Drop Impact

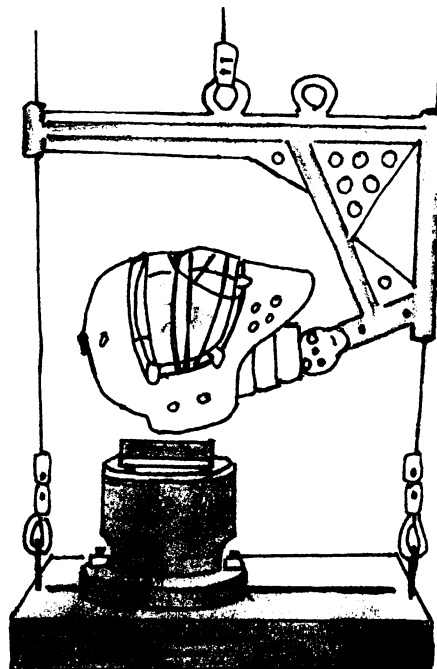

Right Rear Boss Drop Impact

Figure 2

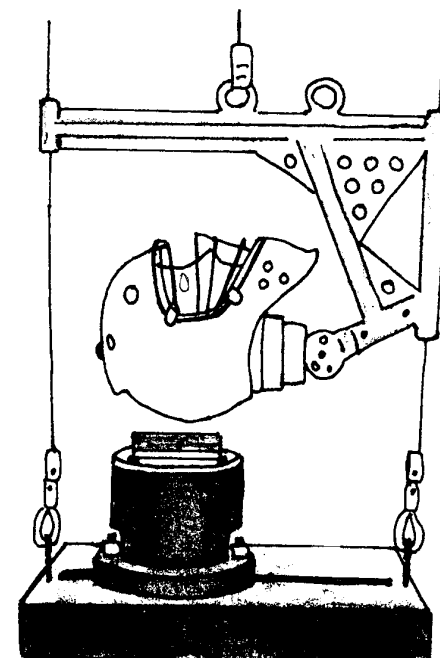

Rear Drop Impact

Catcher's Helmet Anvil

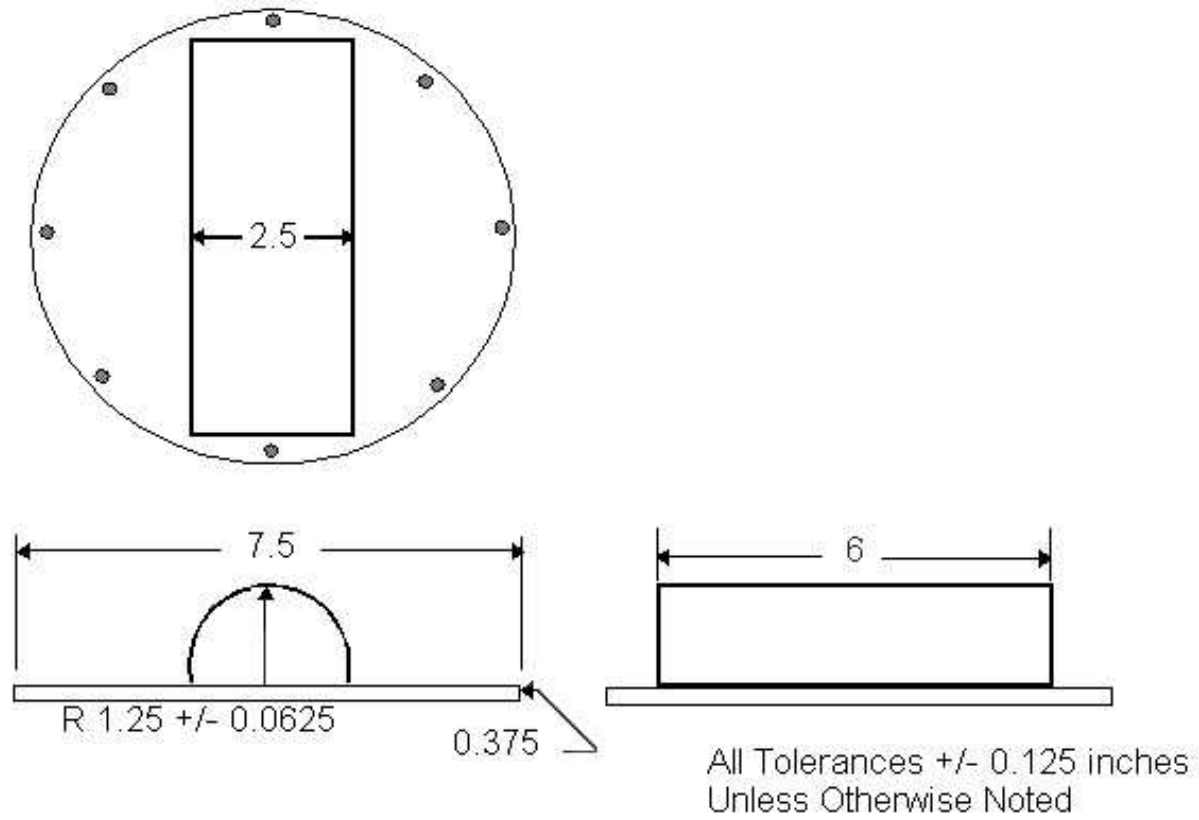
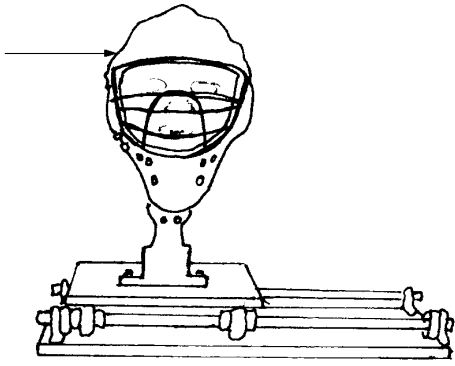
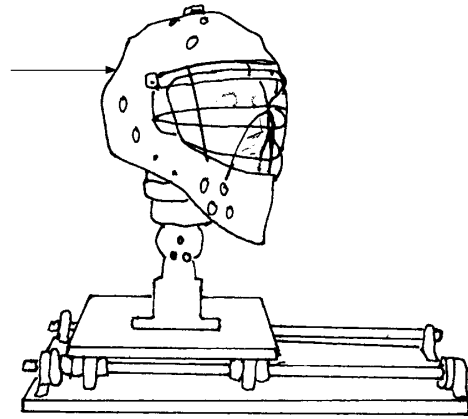

Figure 3



Right Side Projectile Impact



Right Rear Boss Projectile Impact

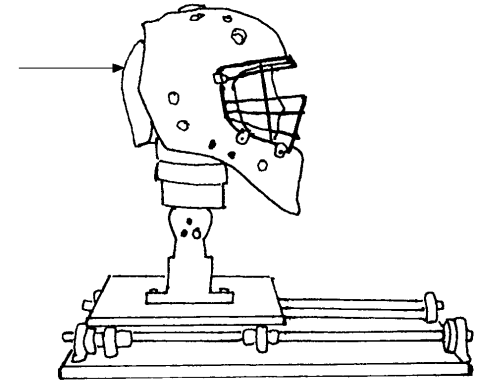

Rear Projectile Impact

Figure 4

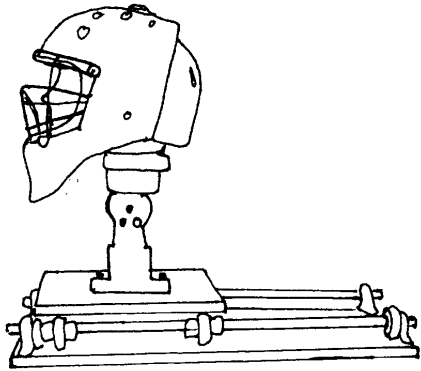

Front Projectile Impact

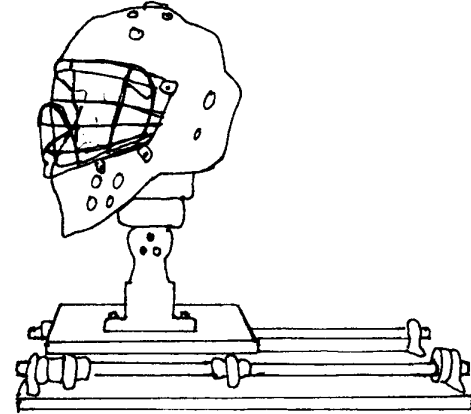

45 Degree Projectile Impact

Figure 5

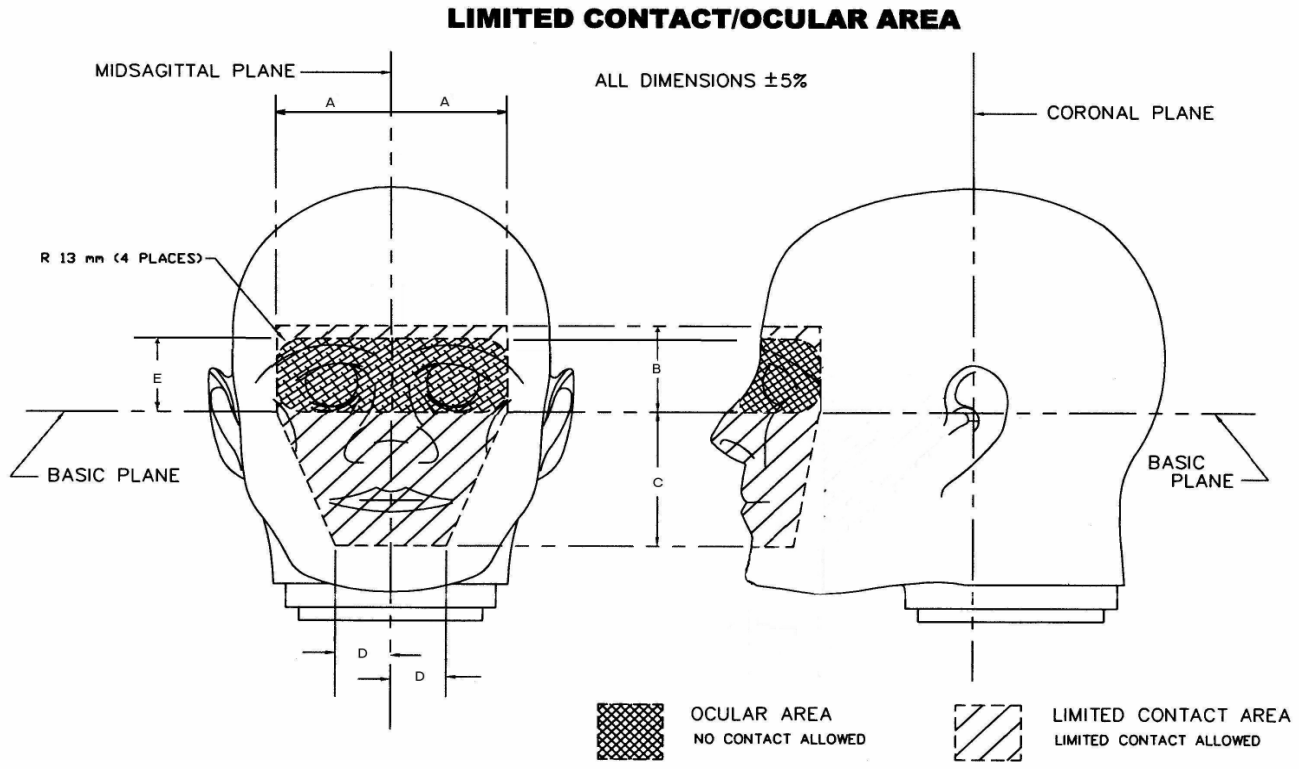

TABLE 4

Headform	Label	A	B	C	D	E
Small	Dimension, mm (in)	54 (2.113)	41 (1.619)	64 (2.518)	26 (1.019)	32 (1.259)
Medium	Dimension, mm (in)	56 (2.205)	45 (1.772)	70 (2.756)	27 (1.062)	35 (1.378)
Large	Dimension, mm (in)	62 (2.421)	50 (1.969)	78 (3.063)	30 (1.167)	39 (1.532)

Figure 6

JANUARY, 2000 MODIFICATIONS/REVISIONS

- Modified 5.3.1.4 and 5.3.1.5 for clarity.
- Changed the random location description in Figure 1 to make it the same as that in NOCSAE DOC.001.
- Modified the drawing in Figure 6 to depict the “ocular, no contact” area.

JANUARY, 2002 MODIFICATIONS/REVISIONS

- Simplified document references within document.
- Modified Figure 1 showing faceguard, and clarified impact locations.

APRIL, 2003 MODIFICATIONS/REVISIONS

- **REVISED**- Defined random impact locations referenced from previous impacts.
- Modified naming convention and added NOCSAE logo to cover page.
- Modified the description of the projectile used.

JANUARY, 2004 MODIFICATIONS/REVISIONS

- Modified section 5.3 Faceguard projectile test to clarify impact order and location options
- Modified Ball specifications for clarity
- Clarified limited contact area in text

DECEMBER, 2005 MODIFICATIONS/REVISIONS

- Clarified and added note to section 5.2.2.2.
- Added tolerances and clarified Figure 3 (Half Steel Anvil drawing).

JUNE, 2006 MODIFICATIONS/REVISIONS

- **REVISED**- Changed the number of samples required to be submitted. Changed the impact projectile and impact schedule. Defined the softball projectile.

DECEMBER 2006 MODIFICATIONS/REVISIONS

- Modified sections 5.1.2 and 5.1.3 to specify weight in ounces of baseball and softballs used.

DECEMBER 2008 MODIFICATIONS/REVISIONS

- Updated Figure 6 to include dimensions for Limited Contact/ Ocular Area on small and large headforms
- Updated effective date from June 08 to June 09

JANUARY 2009 MODIFICATIONS/REVISIONS

- Updated effective date from June 2009 to June 2010

DECEMBER 2009 MODIFICATIONS/REVISIONS

- Corrected Table 4 in Figure 6 dimension A

February 2010 MODIFICATIONS/REVISIONS

- **REVISED**- Changed the impact velocity specified for a softball impact to the helmet. Effective date remains unchanged.
- Specified the number of helmet samples required.
- Clarified test schedule.

MAY 2010 MODIFICATIONS/REVISIONS

- Clarified section 5.2.3.4 statement for selecting baseball impact locations.